



PLANETARY GEAR BOX

ZDR/ZDGF(S)系列
高精度行星减速机



中大 实现自动化应用的无限可能

Zhongda Realizes the infinite possible in automation application

宁波中大力德智能传动股份有限公司始创于1998年，是一家专业制造电机驱动、微特电机、精密减速机的中外合资企业。公司现有员工800人，固定资产2亿元，占地面积100亩（其中杭州湾50亩）。

公司系国家级高新技术企业，浙江省级企业研发中心，获国家专利81项，参与制定国标4项，行标3项；其中以第一起草单位制定国标1项，行标1项；“永磁无刷电机行星齿轮减速机构”列入国家火炬计划，“VRSF-78VR20-200行星减速器”列入国家重点新产品计划，获中国科技部颁发“国家重点新产品证书”。

Ningbo Zhongda Leader Intelligent Transmission Co., Ltd. is a sino-foreign joint venture. specialized in micro motors, motor drivers and precision gear reducers. We have 800 employees, with two hundred million RMB of fixed assets and area of 66666m² (half in Hangzhou Wan).

We, ZD-MOTOR, is a national hi-tech enterprise, and provincial R&D center of Zhejiang, we own 81 national patents, we participated in drafting 4 national standard, 3 industry standards. As major party to draft 1 national and 1 industry standard. "gear reduced permanent brushless motor institution" is listed in National Torch Plan, "VRSF-78VR20-200 planetary gear reducer" is listed in national new major product plan, and gain the certification of "National New Major product" issued by China's Ministry of Science & Technology.

ZDR、ZDGF(S) 系列减速机

ZDR、ZDGF(S) SERIES GEAR BOX

系列号、机型标识说明 Type And Model Number

ZDR、ZDGF(S)减速机 ZDR、ZDGF(S) Reducers	伺服电机 Servo Motor
--	---------------------

$\frac{78}{\textcircled{1}}$ $\frac{ZDR}{\textcircled{2}}$ $\frac{20}{\textcircled{3}}$ $\frac{()}{\textcircled{4}}$ $\frac{(S)}{\textcircled{5}}$ - $\frac{750}{\textcircled{6}}$ $\frac{T1}{\textcircled{7}}$ $\frac{\square}{\textcircled{8}}$

① 减速机机座号:ZDR:52,78,98,125 ZDGF(S):60,90,120,170	Gear head frame size:ZDR:52,78,98,125 ZDGF(S):60,90,120,170				
② 减速机系列代号:ZDR:斜齿精密型 ZDGF:斜齿法兰盘输出型 ZDGS:斜齿轴输出型	Gear head series code: ZDR:Oblique tooth precision ZDGF:Helical flange plate output ZDGS:Helical shaft output				
③ 减速比:ZDR:单级3,4,5,6,7,8,9,10; 两级15,20,25,35,45,81 ZDGF(S):单级※3.67,4,5,7,9,10; 两级11,15(15.4),20,21,25,33,35,40,45, 50,70,81,100(0,120,170的减速比为15.4)	Gear Ratio: ZDR: Single Stage 3,4,5,6,7,8,9,10; Two Stages 15,20,25,35,45,81 ZDGF(S): Single Stage ※3.67,4,5,7,9,10; Two Stages 1,15(15.4),20,21,25,33,35,40,45,50,70,81,100 (90,120,170 reduction ratio is15.4)				
④ 精度 Amount of backlash 输出轴负荷量为容许输出扭矩的±5%时的值 precision (the load of output shaft is±5% of allowable output torque)	机型号 Reducer Type No.	级数 Stage	标准型P2(省略) Standard Type	精密型P1 Low-backlash Type	高精型P0 High Precision Type
	52ZDR	1	12分arc-min	10分arc-min	3分arc-min
		2	15分arc-min	12分arc-min	5分arc-min
	78ZDR	1	8分arc-min	5分arc-min	3分arc-min
		2	12分arc-min	8分arc-min	5分arc-min
	98ZDR	1	8分arc-min	5分arc-min	3分arc-min
		2	12分arc-min	8分arc-min	5分arc-min
	125ZDR	1	8分arc-min	5分arc-min	3分arc-min
		2	12分arc-min	8分arc-min	5分arc-min
	60-170ZDGF(S)	1	5分arc-min	3分arc-min	-
		2	8分arc-min	5分arc-min	-
⑤ 输出轴型式 S:整体锁紧(省略)(无论马达是否有键槽都可用,但“D”字型不适用) S1:带锁紧环锁紧(无论马达是否有键槽都可用,但“D”字型不适用) S2:带键槽锁紧(输入轴带键) K:带键槽 A:其他适配器(请与本公司联系)	nput shaft type S:Overall locking(Omission)(regardless whether the motor with keyway can use it. But D Cut can't use) S1:Locking with locking ring(regardless whether the motor with keyway can use it, But D Cut can't use) S2:Locking with keyway (input shaft with key) K:With keyway A:Other type (please contact with us)				
⑥ 适用伺服马达功率(W)	Applicable servo motor power (W)				
⑦ 伺服马达厂家名称(P43)	Manufacturer name of servo motor (P43)				
⑧ 伺服马达型号	Model of servo motor				

※ 1:3.67 是3/11=1/3.666.....

ZDR 减速比、机型号

ZDR REDUCTION RATIO & TYPE NUMBER

剖视图 Sectional Drawing

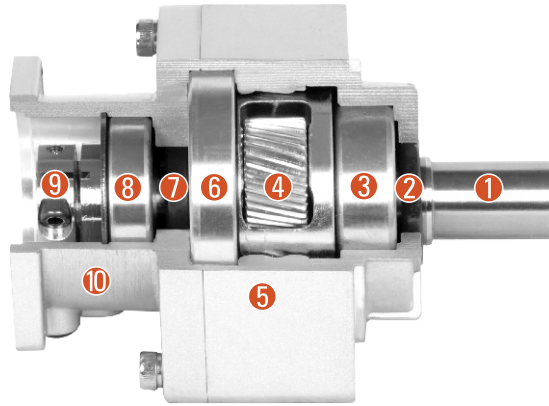

- ① 输出轴 Output shaft
- ② 油封 Seal for the output shaft
- ③ 输出轴前轴承 Bearing for the output shaft
- ④ 行星轮 Planetary gear
- ⑤ 前盖 Front cover
- ⑥ 输出轴后轴承 Bearing for the output shaft
- ⑦ 油封 Seal for the output shaft
- ⑧ 输入轴轴承 Bearing for the input shaft
- ⑨ 精密装夹系统 Precision clamping system
- ⑩ 后盖 Rear cover

输入转速为3000rpm时 When Input Speed is 3000rpm

减速比Reduction Ratio	单级减速 1 Stage Reduction			两级减速 2 Stage Reduction					
	1/3	1/5	1/9	1/15	1/20	1/25	1/35	1/45	1/81
50W									
100W		52			52				98
200W								98	125
400W					78			98	
750W		78			98			125	
1000W									
1500W	98			125					
2000W									
2500W									
3000W									
3500W									
4000W									
4500W									
5000W									

注1) 全部为斜齿轮适用范围 Note1) All corresponding to helical gear

输入转速为2000rpm时 When Input Speed is 2000rpm

减速比Reduction Ratio	单级减速 1 Stage Reduction			两级减速 2 Stage Reduction					
	1/3	1/5	1/9	1/15	1/20	1/25	1/35	1/45	1/81
50W									
100W		52			52				
200W								98	
400W					78				
750W		78			98				
1000W									
1500W	98			125					
2000W									
2500W									
3000W									
3500W									

注1) 全部为斜齿轮适用范围
Note1) All corresponding to helical gear

※以下为限扭矩机种:
52: 1/5减速(100W)
78: 1/81减速(50W)
98: 1/3减速(1500W)、1/45减速(200W)
1/81减速(100W)
125: 1/3减速(3500W)、1/25减速(750W)

※Torque is limited to the following types:
52: 1/5 reduction(100W)
78: 1/81 reduction(50W)
98: 1/3 reduction(1500W), 1/45 reduction(200W)
1/81 reduction(100W)
125: 1/3 reduction(3500W), 1/25 reduction(250W)

关于润滑油 About Lubricant

• 润滑: 润滑脂 • 更换: 不可

• Lubrication: Grease

• Replacement: Not available

ZDR性能表 (输入转速为3,000rpm时)

ZDR PERFORMANCE TABLE (WHEN INPUT SPEED IS 3000RPM)

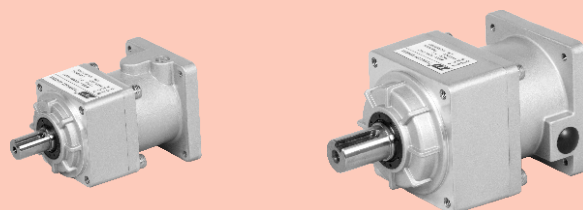

性能表 Performance Table

减速比 Reduction Ratio	系列号 Model				输出轴 转速 Shaft Speed (rpm)	额定输出 扭矩 Standard Output Torque (N.m)	瞬间最大 输出扭矩 Instantaneous max.Output Torque (N.m)	容许径向 负荷 Permissible Radial Load (N)	容许轴向 负荷 Permissible Axial Load (N)	输入轴换算 内部惯性力矩 Internal Moment Of inertia Of Input Shaftconversion ($\times 10^{-4}$ kg.m ²)	容许输出 扭矩 Permissible Output Torque (N.m)	瞬间最大容 许输出扭矩 Instantaneous Max. Permissible Output Torque (N.m)
	机座号 Type No.	系列号 Model	减速比 Reduction Ratio	马达功率 Motor								
1/3	52	ZDR	3	-50	1000	0.255	0.784	392	196	0.0575	3.43	10.3
	52	ZDR	3	-100	1000	0.715	2.06	392	196	0.0575	3.43	10.3
	52	ZDR	3	-200	1000	1.47	4.51	392	196	0.135	3.43	10.3
	52	ZDR	3	-400	1000	3.43	10.3	392	196	0.145	3.43	10.3
	78	ZDR	3	-750	1000	6.37	19.3	784	392	0.913	6.86	20.6
	98	ZDR	3	-1000	1000	7.55	22.8	882	441	2.43	18.3	54.9
	98	ZDR	3	-1500	1000	12.3	37.1	882	441	2.43	18.3	54.9
	98	ZDR	3	-2000	1000	17.2	51.5	882	441	2.43	18.3	54.9
	125	ZDR	3	-2500	1000	19.0	57.2	1370	686	5.55	44.1	132
	125	ZDR	3	-3000	1000	23.7	71.2	1370	686	5.50	44.1	132
	125	ZDR	3	-3500	1000	28.3	85.2	1370	686	5.50	44.1	132
	125	ZDR	3	-4000	1000	33.1	99.0	1370	686	5.78	44.1	132
125	ZDR	3	-4500	1000	37.7	113	1370	686	5.78	44.1	132	
125	ZDR	3	-5000	1000	42.9	128	1370	686	5.78	44.1	132	
1/5	52	ZDR	5	-50	600	0.510	1.47	490	245	0.04	1.57	4.70
	52	ZDR	5	-100	600	1.18	3.72	490	245	0.04	1.57	4.70
	52	ZDR	5	-200	600	2.65	8.04	490	245	0.118	2.84	8.53
	78	ZDR	5	-400	600	5.39	16.2	980	490	0.363	6.57	19.7
	78	ZDR	5	-750	600	10.7	32.1	980	490	0.713	11.5	34.3
	98	ZDR	5	-1000	600	13.4	40.5	1080	539	1.85	23.5	70.6
	98	ZDR	5	-1500	600	21.5	64.4	1080	539	1.85	23.5	70.6
	125	ZDR	5	-2000	600	23.8	71.5	1670	833	3.50	56.8	171
	125	ZDR	5	-2500	600	31.8	95.5	1670	833	3.50	56.8	171
	125	ZDR	5	-3000	600	39.6	119	1670	833	3.48	56.8	171
	125	ZDR	5	-3500	600	47.2	141	1670	833	3.48	56.8	171
	125	ZDR	5	-4000	600	55.3	166	1670	833	3.75	56.8	171
1/9	52	ZDR	9	-50	333	0.921	2.74	588	294	0.035	2.35	7.25
	52	ZDR	9	-100	333	2.25	6.86	588	294	0.035	2.35	7.25
	78	ZDR	9	-200	333	3.72	11.3	1180	588	0.275	9.70	29.2
	78	ZDR	9	-400	333	9.51	28.5	1180	588	0.275	9.70	29.2
	98	ZDR	9	-750	333	18.2	54.7	1470	735	0.650	18.2	54.7
	125	ZDR	9	-1000	333	20.0	60.1	1960	980	2.81	73.5	221
	125	ZDR	9	-1500	333	34.3	103	1960	980	2.81	73.5	221
	125	ZDR	9	-2000	333	48.6	146	1960	980	2.81	73.5	221
	125	ZDR	9	-2500	333	60.8	182	1960	980	2.81	73.5	221
	125	ZDR	9	-3000	333	73.0	219	1960	980	2.77	73.5	221

注1) 输入轴换算惯性力矩仅为减速机的数值, 不包括马达的惯性力矩。

注2) 最高输入转速为5000rpm, 正常情况下请将转速控制在3000rpm以下。

注3) 容许径向负荷为输出轴中央部的数值。

注4) 全部为斜齿轮适用范围。

Note1) The moment of input shaft conversion is only gained from the reducer, so it does not include moment of inertia of the motor.

Note2) The max. input speed is 5000rpm. Usually set to 3000rpm or less.

Note3) The permissible radial load is indicated on the center of the output shaft.

Note4) All values are within the range corresponding to helical gear.

ZDR性能表 (输入转速为3,000rpm时)

ZDR PERFORMANCE TABLE (WHEN INPUT SPEED IS 3000RPM)

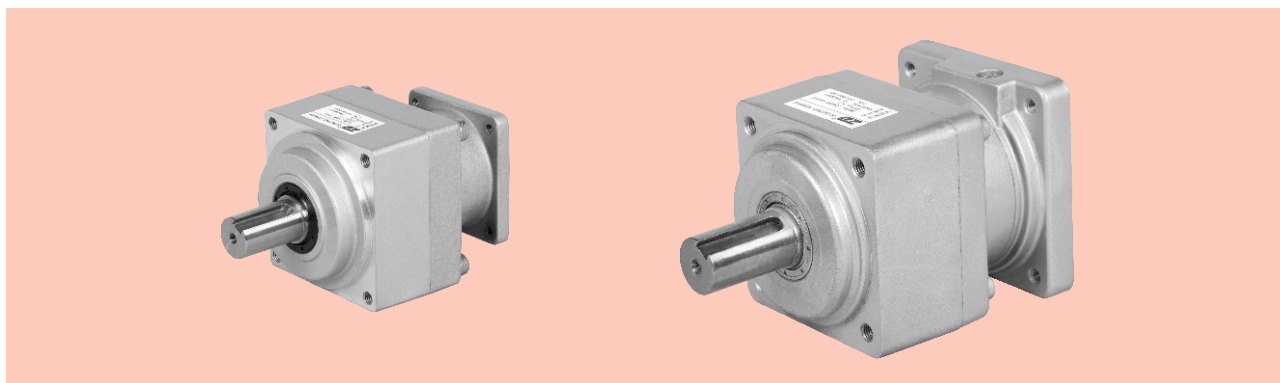

性能表 Performance Table

减速比 Reduction Ratio	系列号 Model				输出轴 转速 Output Shaft Speed (rpm)	额定输出 扭矩 Standard Output Torque (N.m)	瞬间最大 输出扭矩 Instantaneous Max.Output Torque (N.m)	容许径向 负荷 Permissible Radial Load (N)	容许轴向 负荷 Permissible Axial Load (N)	输入轴换算 内部惯性力矩 Internal Moment Of inertia Of Input Shaftconversion ($\times 10^{-4}$ kg.m ²)	容许输出 扭矩 Permissible Output Torque (N.m)	瞬间最大容 许输出扭矩 Instantaneous Max. Permissible Output Torque (N.m)
	机座号 Type No.	系列号 Model	减速比 Reduction Ratio	马达功率 Motor								
1/15	52	ZDR	15	-50	200	1.67	5.00	784	392	0.035	4.02	12.2
	52	ZDR	15	-100	200	3.72	11.4	784	392	0.035	4.02	12.2
	78	ZDR	15	-200	200	6.27	18.8	1470	735	0.300	16.2	48.6
	78	ZDR	15	-400	200	15.8	47.5	1470	735	0.300	16.2	48.6
	98	ZDR	15	-750	200	30.4	91.2	1760	882	0.700	30.4	91.2
	125	ZDR	15	-1000	200	33.3	100	2350	1180	1.95	91.4	274
	125	ZDR	15	-1500	200	57.2	172	2350	1180	2.80	91.4	274
	125	ZDR	15	-2000	200	81.0	243	2350	1180	2.80	91.4	274
1/20	52	ZDR	20	-50	150	2.21	6.63	804	402	0.034	5.00	15.0
	52	ZDR	20	-100	150	5.00	15.0	804	402	0.034	5.00	15.0
	78	ZDR	20	-200	150	8.69	26.1	1570	785	0.294	21.1	63.3
	78	ZDR	20	-400	150	21.1	63.3	1570	785	0.294	21.1	63.3
	98	ZDR	20	-750	150	40.6	122	1910	955	0.690	40.6	122
1/25	52	ZDR	25	-50	120	2.74	8.33	882	441	0.0325	4.02	12.2
	52	ZDR	25	-100	120	6.27	19.0	882	441	0.0325	6.27	19.0
	78	ZDR	25	-200	120	11.1	33.3	1670	833	0.288	21.7	64.9
	78	ZDR	25	-400	120	26.4	79.2	1670	833	0.288	26.4	79.2
	98	ZDR	25	-750	120	50.7	152	2060	1030	0.680	50.7	152
1/35	125	ZDR	25	-1000	120	55.7	167	2650	1320	1.880	65.4	196
	52	ZDR	35	-50	85	3.84	11.5	882	441	0.030	3.84	11.5
	78	ZDR	35	-100	85	7.24	21.7	1670	833	0.065	13.9	41.7
	78	ZDR	35	-200	85	15.5	46.6	1670	833	0.262	15.5	46.6
	98	ZDR	35	-400	85	37.0	111	2060	1030	0.269	37.0	111
1/45	125	ZDR	35	-750	85	71.0	213	3430	1715	0.473	71.0	213
	78	ZDR	45	-50	66	3.86	11.6	1670	833	0.0285	9.50	28.6
	78	ZDR	45	-100	66	9.31	28.0	1670	833	0.0285	9.50	28.6
	98	ZDR	45	-200	66	21.1	63.5	2060	1030	0.0256	28.3	85.2
	125	ZDR	45	-400	66	47.5	142.5	3520	1760	0.245	57.0	171
1/81	125	ZDR	45	-750	66	91.3	274	3520	1760	1.770	91.3	274
	78	ZDR	81	-50	37	7.02	20.8	1670	833	0.027	9.70	29.2
	98	ZDR	81	-100	37	14.0	42.0	2060	1030	0.030	17.8	53.5
	125	ZDR	81	-200	37	36.1	108.3	3530	1765	0.240	43.3	129.9

注1) 输入轴换算惯性力矩仅为减速机的数值, 不包括马达的惯性力矩。
 注2) 最高输入转速为5000rpm, 正常情况下请将转速控制在3000rpm以下。
 注3) 容许径向负荷为输出轴中央部的数值。
 注4) 全部为斜齿轮适用范围。

Note1) The moment of input shaft conversion is only gained from the reducer, so it does not include moment of inertia of the motor.
 Note2) The max. input speed is 5000rpm. Usually set to 3000rpm or less.
 Note3) The permissible radial load is indicated on the center of the output shaft.
 Note4) All values are within the range corresponding to helical gear.

ZDR性能表 (输入转速为2,000rpm时)

ZDR PERFORMANCE TABLE (WHEN INPUT SPEED IS 2000RPM)

性能表 Performance Table

标准型、P1(精密型)、P2(高精密型)均为相同的规格 The same specification applies to all of standard type, P1(low backlash), and P2(high precision type).

减速比 Reduction Ratio	系列号 Model				输出轴 转速 Outout Shaft Speed	额定输出 扭矩 Standard Output Torque	瞬间最大 输出扭矩 Instantaneous Max.Output Torque	容许径向 负荷 Permissible Radial Load	容许轴向 负荷 Permissible Axial Load	输入轴换算 内部惯性力矩 Of Input Shaftconversion Internal Moment Ofinertia	容许输出 扭矩 Permissible Output Torque	瞬间最大容 许输出扭矩 Instantaneous Max. Permissible Output Torque		
	机座号 Type No.	系列号 Model	减速比 Reduction Ratio	马达功率 Motor										
					(rpm)	(N.m)	(N.m)	(N)	(N)	($\times 10^{-4}$ kg.m ²)	(N.m)	(N.m)		
1/3	52	ZDR	3	-50	666	0.477	1.43	450	225	0.0575	3.43	10.3		
	52	ZDR	3	-100	666	1.05	3.15	450	225	0.135	3.43	10.3		
	52	ZDR	3	-200	666	2.48	7.45	450	225	0.145	3.43	10.3		
	78	ZDR	3	-400	666	5.01	15.0	900	450	0.913	6.86	20.6		
	98	ZDR	3	-750	666	8.73	26.2	1010	505	2.43	18.3	54.9		
	98	ZDR	3	-1000	666	12.3	37.1	1010	505	2.43	18.3	54.9		
	98	ZDR	3	-1500	666	18.3	54.9	1010	505	2.43	18.3	54.9		
	125	ZDR	3	-2000	666	23.7	71.2	1570	785	5.50	44.1	132		
	125	ZDR	3	-2500	666	30.8	92.5	1570	785	5.50	44.1	132		
	125	ZDR	3	-3000	666	37.7	113	1570	785	5.50	44.1	132		
	125	ZDR	3	-3500	666	44.1	132	1570	785	5.78	44.1	132		
	1/5	52	ZDR	5	-50	400	0.795	2.39	560	280	0.040	1.57	4.70	
52		ZDR	5	-100	400	1.57	4.70	560	280	0.118	1.57	4.70		
78		ZDR	5	-200	400	3.82	11.5	1120	560	0.363	6.57	19.7		
78		ZDR	5	-400	400	8.35	25.1	1120	560	0.713	11.5	34.3		
98		ZDR	5	-750	400	15.5	46.5	1230	615	1.85	23.5	70.6		
98		ZDR	5	-1000	400	21.5	64.4	1230	615	1.85	23.5	70.6		
125		ZDR	5	-1500	400	27.8	83.5	1900	950	3.50	56.8	171		
125		ZDR	5	-2000	400	39.6	119	1900	950	3.48	56.8	171		
125		ZDR	5	-2500	400	51.4	154	1900	950	3.75	56.8	171		
1/9		52	ZDR	9	-50	222	1.57	4.72	670	335	0.035	2.35	7.25	
		78	ZDR	9	-100	222	2.35	7.04	1340	670	0.275	9.70	29.2	
		78	ZDR	9	-200	222	6.64	19.9	1340	670	0.275	9.70	29.2	
	98	ZDR	9	-400	222	14.0	41.9	1680	840	0.650	18.2	54.7		
	125	ZDR	9	-750	222	23.6	70.9	2240	1120	2.81	73.5	221		
	125	ZDR	9	-1000	222	34.3	103	2240	1120	2.81	73.5	221		
	125	ZDR	9	-1500	222	53.7	161	2240	1120	2.81	73.5	221		
	125	ZDR	9	-2000	222	73.0	219	2240	1120	2.77	73.5	221		
	1/15	52	ZDR	15	-50	133	2.62	7.87	882	441	0.035	4.02	12.2	
		78	ZDR	15	-100	133	3.91	11.7	1670	833	0.300	16.2	48.6	
		78	ZDR	15	-200	133	11.1	33.2	1670	833	0.300	16.2	48.6	
		98	ZDR	15	-400	133	23.3	69.8	2020	1010	0.700	30.4	91.2	
125		ZDR	15	-750	133	39.4	118	2650	1320	2.80	91.4	274		
125		ZDR	15	-1000	133	57.2	172	2650	1320	2.80	91.4	274		
125		ZDR	15	-1500	133	91.3	274	2650	1320	2.80	91.4	274		
1/20		52	ZDR	20	-50	100	3.50	10.5	910	455	0.034	5.00	15.0	
		78	ZDR	20	-100	100	5.73	17.2	1790	895	0.294	21.1	63.3	
		78	ZDR	20	-200	100	14.8	44.4	1790	895	0.294	21.1	63.3	
		98	ZDR	20	-400	100	31.0	93.1	2180	1090	0.294	40.6	122	
		1/25	52	ZDR	25	-50	80.0	4.37	13.1	882	441	0.0325	6.27	19.0
	78		ZDR	25	-100	80.0	7.16	21.5	1670	833	0.288	21.7	64.9	
	78		ZDR	25	-200	80.0	18.5	55.4	1670	833	0.288	21.7	64.9	
	98		ZDR	25	-400	80.0	38.8	116	2060	1030	0.680	50.7	152	
	125		ZDR	25	-750	80.0	65.4	196	2650	1320	1.88	65.4	196	
	1/35		78	ZDR	35	-50	57.0	4.43	13.3	1900	950	0.262	15.5	46.6
			78	ZDR	35	-100	57.0	12.7	38.1	1900	950	0.262	15.5	46.6
			98	ZDR	35	-200	57.0	22.0	66.0	2340	1170	0.269	37.0	111
1/45			78	ZDR	45	-50	44.4	5.80	17.4	1670	833	0.0285	9.50	28.6
			98	ZDR	45	-100	44.4	14.0	42.1	2060	1030	0.0285	28.3	85.2
			98	ZDR	45	-200	44.4	28.3	85.2	2060	1030	0.0285	28.3	85.2
			1/81	78	ZDR	81	-50	24.6	9.70	29.2	1670	833	0.0270	9.70
		98		ZDR	81	-100	24.6	17.8	53.5	2060	1030	0.0300	17.8	53.5

注1) 输入轴换算惯性力矩仅为减速机的数值, 不包括马达的惯性力矩。

注2) 容许径向负荷为输出轴中央部的数值。

注3) 全部为斜齿轮适用范围。

Note1) The moment of input shaft conversion is only gained from the reducer, so it does not include moment of inertia of the motor.

Note2) The permissible radial load is indicated on the center of the output shaft.

Note3) All values are within the range corresponding to helical gear.

ZDR同芯轴型减速机尺寸表

DIMENSIONAL TABLE FOR ZDR CONCENTRIC SHAFT REDUCER

机械参数 Dimensions

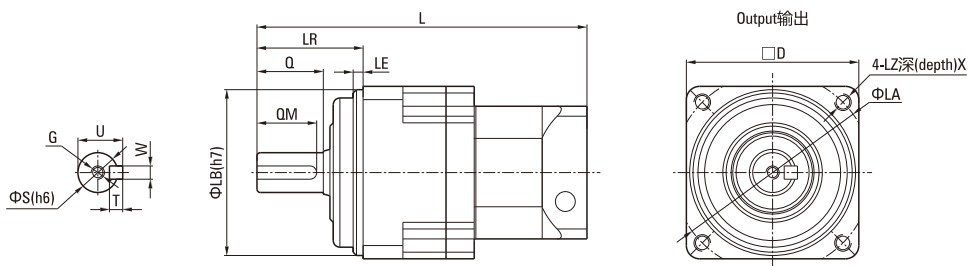

尺寸表 Dimensional Table

型号 Type				全长 Total Length L			输出轴 Output Shaft						法兰 Flange							
机座号 Type No.	系列号 Model	减速比 Reduction Ratio	马达功率 Motor	松下电器生产 Panasonic- made MSMA	安川电机生产 Yaskawa-made SGMASH SGMSH	三菱电机生产 Mitsubishi-made HC-KFS HC-RFS	LR	S	Q	QM	QM	W×U	T	D	LB	LE	LA	LZ	X	
52	ZDR	3-5-9	50																	
52	ZDR	15-20-25-35	50																	
52	ZDR	3-5-9	100				32	12	20	18	M4(depth)12	4×13.5	4	52	50	3	60	M5	12	
52	ZDR	15-20-25	100																	
52	ZDR	3-5	200																	
52	ZDR	3	400																	
78	ZDR	45-81	50																	
78	ZDR	35	100																	
78	ZDR	45	100																	
78	ZDR	9	200				50	19	30	26	M5(depth)15	6×21.5	6	80	70	3	90	M6	20	
78	ZDR	15-20-25-35	200																	
78	ZDR	5-9	400																	
78	ZDR	15-20-25	400																	
78	ZDR	3-5	750																	
98	ZDR	81	100																	
98	ZDR	45	200																	
98	ZDR	35	400																	
98	ZDR	9	750				61	24	40	35	M6(depth)20	8×27	7	100	90	5	115	M8	20	
98	ZDR	15-20-25	750																	
98	ZDR	3.5	1000																	
98	ZDR	3.5	1500																	
98	ZDR	3	2000																	
125	ZDR	81	200																	
125	ZDR	45	400																	
125	ZDR	35	750																	
125	ZDR	45	750																	
125	ZDR	9	1000																	
125	ZDR	15-25	1000																	
125	ZDR	9	1500																	
125	ZDR	15	1500																	
125	ZDR	5-9	2000				75	32	55	52	M10(depth)20	10×35	8	125	110	5	135	M10	20	
125	ZDR	15	2000																	
125	ZDR	3-5-9	2500	215	-	-														
125	ZDR	3-5-9	3000	215	225	-														
125	ZDR	3.5	3500	215	-	225														
125	ZDR	3.5	4000	225	225	-														
125	ZDR	3	4500	225	-	-														
125	ZDR	3	5000		225															

注1) 基准系列(马达对应表记载系列)以外的马达, 请咨询。(因为根据马达安装的不同法兰尺寸可能不同)

注2) 输出轴旋转方向与马达输入旋转方向相同。

注3) 全部为斜齿轮适用范围。

Note1) Please inquire to us if motor model isn't standard (Matching motor list). (The flange dimension may be different if motor assension is different.)

Note2) Rotation of the output shaft is in the same direction as that of motor input.

Note3) All values are within the range corresponding to helical gear.

50W尺寸图与性能表

50W DIMENSIONAL DRAWING & PERFORMANCE TABLE

性能表 Performance Table (输入转速为3,000rpm时 When Input Speed Is 3000rpm)

额定输入 马达功率 Rated Input Motor	减速比 Reduction Ratio	系列号 Model				输出轴 转速 Outout Shaft Speed (rpm)	额定输出 扭矩 Standard Output Torque (N.m)	瞬间最大 输出扭矩 Instantaneous Max.Output Torque (N.m)	容许径向 负荷 Permissible Radial Load (N)	容许轴向 负荷 Permissible Axial Load (N)	输入轴换算 内部惯性力矩 Internal Moment Of inertia Of Input Shaftconversion ($\times 10^{-4}$ kg.m ²)	容许输出 扭矩 Permissible Output Torque (N.m)	瞬间最大容 许输出扭矩 Instantaneous Max. Permissible Output Torque (N.m)
		机座号 Type No.	系列号 Model	减速比 Reduction Ratio	马达功率 Motor								
50W	1/3	52	ZDR	3	50	1000	0,255	0,784	392	196	0,0575	3,43	10,3
	1/5	52	ZDR	5	50	600	0,510	1,47	490	245	0,0400	1,57	4,70
	1/9	52	ZDR	9	50	333	0,921	2,74	588	294	0,0350	2,35	7,25
	1/15	52	ZDR	15	50	200	1,67	5,00	784	392	0,0350	4,02	12,2
	1/20	52	ZDR	20	50	150	2,21	6,63	804	402	0,0340	5,00	15,0
	1/25	52	ZDR	25	50	120	2,74	8,33	882	441	0,0325	4,02	12,2
	1/35	52	ZDR	35	50	85	3,84	11,5	882	441	0,0300	3,84	11,5
	1/45	78	ZDR	45	50	66	3,86	11,6	1670	833	0,0285	9,50	28,6
	1/81	78	ZDR	81	50	37	7,02	20,8	1670	833	0,0270	9,70	29,2

注1) 安装基准系列(马达适用表记载系列)以外的马达时, 每次都是与我们联系。(法兰尺寸可能不同)

注2) 输入轴换算惯性力矩仅为减速机的数值, 不包括马达的惯性力矩。

注3) 最高输入转速为5000rpm。正常情况下请转速控制在3000rpm以下。

注4) 容许径向负荷表示输出轴中央部位的值。

注5) 全部为斜齿轮适用范围。

注6) 马达的安装顺序请参考P31。

注7) 输出轴旋转方向与马达输入旋转方向相同。

Note1) In case of attachment to a motor beyond the standard models(motor matching series), contact us. (How to measure dimensions of the flange may be changed in some cases.)

Note2) The moment of inertia of input shaft conversion is only gained from the reducer, so it does not include moment of inertia of the motor.

Note3) The max. input speed is 5000rpm, and usually set to 3000rpm or less.

Note4) The permissible radial load is indicated on the center of the output shaft.

Note5) All values are within the range corresponding to helical gear.

Note6) For motor assembly procedure, see page 31.

Note7) Rotation of the output shaft is in the same direction as motor.

尺寸表 Dimensions

● 52ZDR3-5-9-50

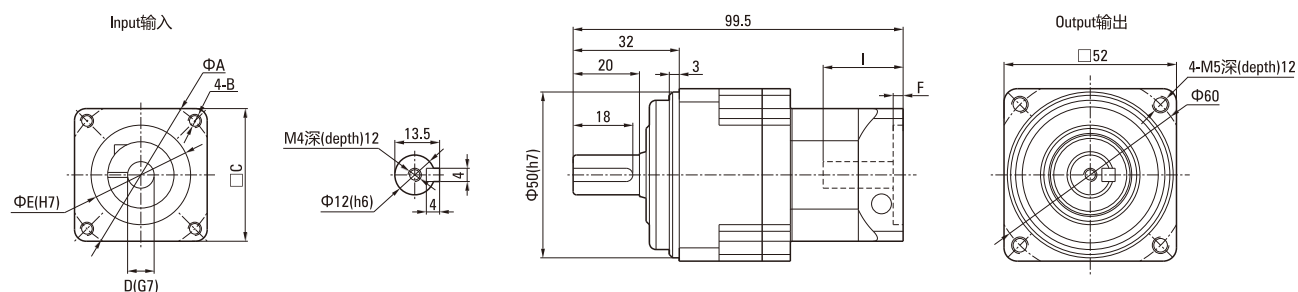

● 法兰部位详细尺寸表 Detailed Flange Dimensions Table

(单位Unit:mm)

马达种类 Motor Type	A	B	C	D	E	F	I
T1	45	M3深(depth)6.5	40	8	30	4	26
T2	46	M4深(depth)6.5	40	6	30	4	26
T3	46	M4深(depth)6.5	40	8	30	4	26

● 概略重量0,55kg

Rough weight 0,55kg

● T1~3的详细情况请参考P.43

For details of T1~3, see page 43

50W尺寸图与性能表

50W DIMENSIONAL DRAWING & PERFORMANCE TABLE

■ 尺寸表 Dimensions

● 52ZDR15-20-25-35-50

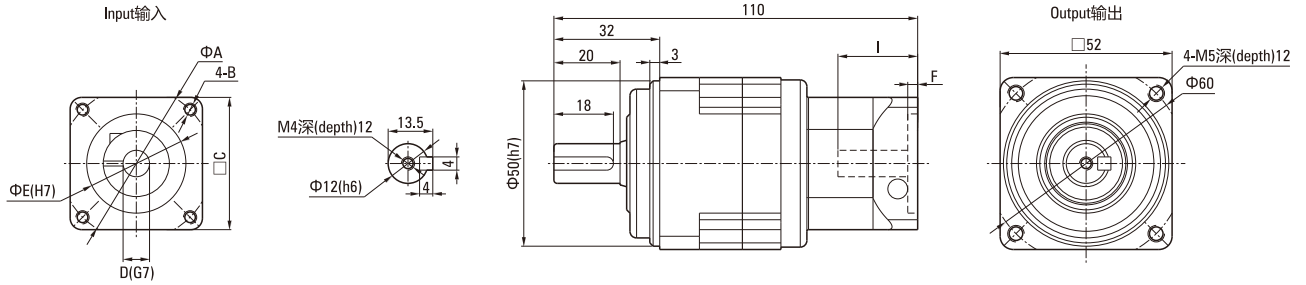

● 法兰部位详细尺寸表 Detailed Flange Dimensions Table

(单位Unit:mm)

马达种类 Motor Type	A	B	C	D	E	F	I
T1	45	M3深(depth)6.5	40	8	30	4	26
T2	46	M4深(depth)6.5	40	6	30	4	26
T3	46	M4深(depth)6.5	40	8	30	4	26

• 概略重量0.7kg

Rough weight 0.7kg

• T1~3的详细情况请参照P43

For details of T1~3, see page 43

● 78ZDR45-81-50

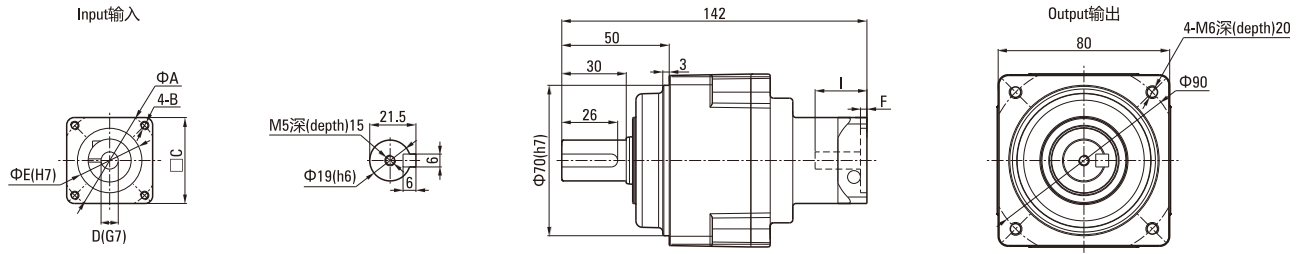

● 法兰部位详细尺寸表 Detailed Flange Dimensions Table

(单位Unit:mm)

马达种类 Motor Type	A	B	C	D	E	F	I
T1	45	M3深(depth)6.5	40	8	30	4	26
T2	46	M4深(depth)6.5	40	6	30	4	26
T3	46	M4深(depth)6.5	40	8	30	4	26

• 概略重量1.7kg

Rough weight 1.7kg

• T1~3的详细情况请参照P43

For details of T1~3, see page 43

100W尺寸图与性能表

100W DIMENSIONAL DRAWING & PERFORMANCE TABLE

性能表 Performance Table (输入转速为3,000rpm时 When Input Speed Is 3000rpm)

额定输入 马达功率 Rated Input Motor	减速比 Reduction Ratio	系列号 Model				输出轴 转速 Outout Shaft Speed (rpm)	额定输出 扭矩 Standard Output Torque (N.m)	瞬间最大 输出扭矩 Instantaneous Max.Output Torque (N.m)	容许径向 负荷 Permissible Radial Load (N)	容许轴向 负荷 Permissible Axial Load (N)	输入轴换算 内部惯性力矩 Internal Moment Of Inertia Of Input Shaftconversion ($\times 10^{-4}$ kg.m ²)	容许输出 扭矩 Permissible Output Torque (N.m)	瞬间最大容 许输出扭矩 Instantaneous Max. Permissible Output Torque (N.m)
		机座号 Type No.	系列号 Model	减速比 Reduction Ratio	马达功率 Motor								
100W	1/3	52	ZDR	3	100	1000	0,715	2,06	392	196	0,0575	3,43	10,3
	1/5	52	ZDR	5	100	600	1,18	3,72	490	245	0,0400	1,57	4,70
	1/9	52	ZDR	9	100	333	2,25	6,86	588	294	0,0350	2,35	7,25
	1/15	52	ZDR	15	100	200	3,72	11,4	784	392	0,0350	4,02	12,2
	1/20	52	ZDR	20	100	150	5,00	15,0	804	402	0,0340	5,00	15,0
	1/25	52	ZDR	25	100	120	6,27	19,0	882	441	0,0325	6,27	19,0
	1/35	78	ZDR	35	100	85	7,24	21,7	1670	833	0,0650	13,9	41,7
	1/45	78	ZDR	45	100	66	9,31	28,0	1670	833	0,0285	9,50	28,6
	1/81	98	ZDR	81	100	37	14,0	42,0	2060	1030	0,0300	17,8	53,5

注1) 安装基准系列(马达适用表记载系列)以外的马达时, 每次都是与我们联系。(法兰尺寸可能不同)

注2) 输入轴换算惯性力矩仅为减速机的数值, 不包括马达的惯性力矩。

注3) 最高输入转速为5000rpm。正常情况下请转速控制在3000rpm以下。

注4) 容许径向负荷表示输出轴中央部位的值。

注5) 全部为斜齿轮适用范围。

注6) 马达的安装顺序请参照P.31。

注7) 输出轴旋转方向与马达输入旋转方向相同。

Note1) In case of attachment to a motor beyond the standard models(motor matching series), contact us. (How to measure dimensions of the flange may be changed in some cases.)

Note2) The moment of inertia of input shaft conversion is only gained from the reducer, so it does not include moment of inertia of the motor.

Note3) The max. input speed is 5000rpm, and usually set to 3000rpm or less.

Note4) The permissible radial load is indicated on the center of the output shaft.

Note5) All values are within the range corresponding to helical gear.

Note6) For motor assembly procedure, see page 31.

Note7) Rotation of the output shaft is in the same direction as motor.

尺寸表 Dimensions

● 52ZDR3-5-9-100

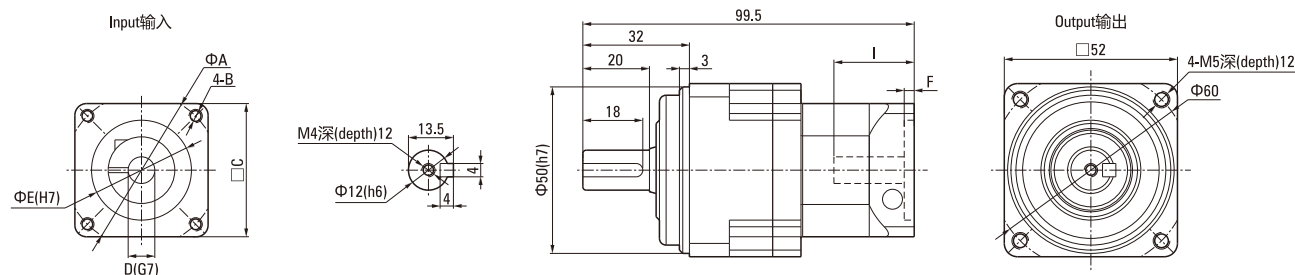

● 法兰部位详细尺寸表 Detailed Flange Dimensions Table

(单位Unit:mm)

马达种类 Motor Type	A	B	C	D	E	F	I
T1	45	M3深(depth)6.5	40	8	30	4	26
T2	46	M4深(depth)6.5	40	8	30	4	26
T3	46	M4深(depth)6.5	40	8	30	4	26

- 概略重量0.55kg
Rough weight 0.55kg
- T1~3的详细情况请参照P.43
For details of T1~3, see page 43

● 52ZDR15-20-25-100

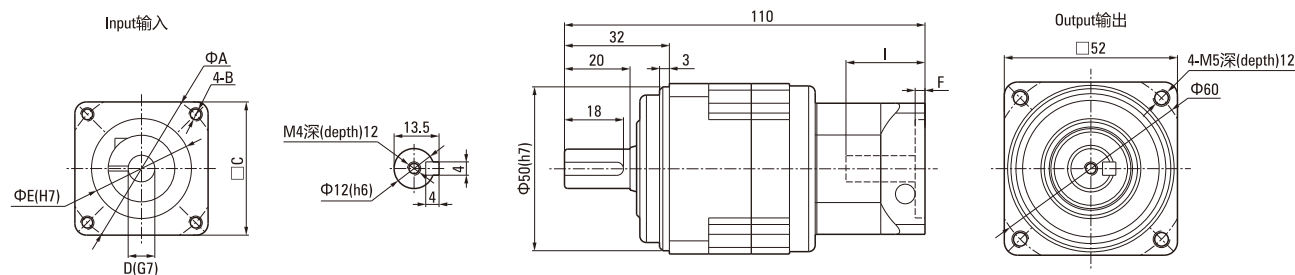

● 法兰部位详细尺寸表 Detailed Flange Dimensions Table

(单位Unit:mm)

马达种类 Motor Type	A	B	C	D	E	F	I
T1	45	M3深(depth)6.5	40	8	30	4	26
T2	46	M4深(depth)6.5	40	8	30	4	26
T3	46	M4深(depth)6.5	40	8	30	4	26

- 概略重量0.7kg
Rough weight 0.7kg
- T1~3的详细情况请参照P.43
For details of T1~3, see page 43

100W尺寸图与性能表

100W DIMENSIONAL DRAWING & PERFORMANCE TABLE

尺寸表 Dimensions

● 78ZDR35-100

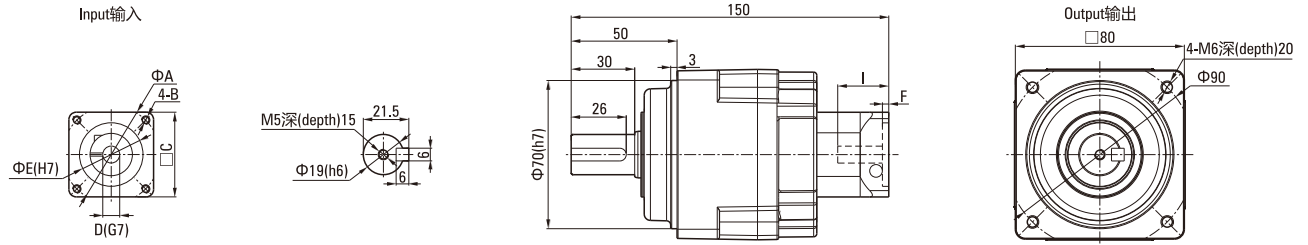

● 法兰部位详细尺寸表 Detailed Flange Dimensions Table

(单位Unit:mm)

马达种类 Motor Type	A	B	C	D	E	F	I
T1	45	M3深(depth)6.5	40	8	30	4	26
T2	46	M4深(depth)6.5	40	8	30	4	26
T3	46	M4深(depth)6.5	40	8	30	4	26

- 概略重量2.0kg
Rough weight 2.0kg
- T1~3的详细情况请参照P43
For details of T1~3, see page 43

● 78ZDR45-100

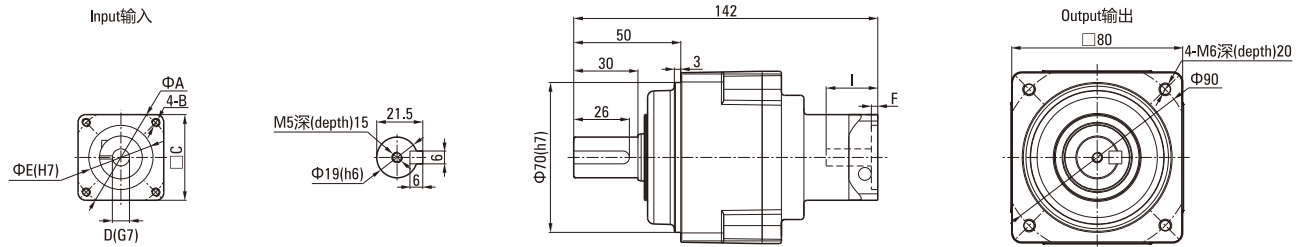

● 法兰部位详细尺寸表 Detailed Flange Dimensions Table

(单位Unit:mm)

马达种类 Motor Type	A	B	C	D	E	F	I
T1	45	M3深(depth)6.5	40	8	30	4	26
T2	46	M4深(depth)6.5	40	8	30	4	26
T3	46	M4深(depth)6.5	40	8	30	4	26

- 概略重量1.7kg
Rough weight 1.7kg
- T1~3的详细情况请参照P43
For details of T1~3, see page 43

● 98ZDR81-100

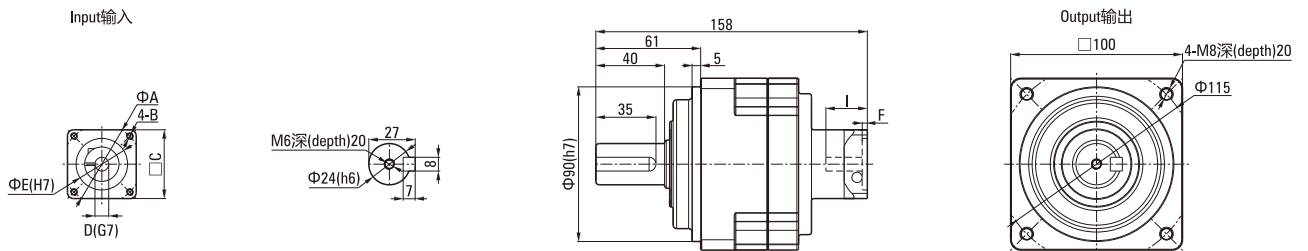

● 法兰部位详细尺寸表 Detailed Flange Dimensions Table

(单位Unit:mm)

马达种类 Motor Type	A	B	C	D	E	F	I
T1	45	M3深(depth)6.5	40	8	30	4	26
T2	46	M4深(depth)6.5	40	8	30	4	26
T3	46	M4深(depth)6.5	40	8	30	4	26

- 概略重量3.0kg
Rough weight 3.0kg
- T1~3的详细情况请参照P43
For details of T1~3, see page 43

200W尺寸图与性能表

200W DIMENSIONAL DRAWING & PERFORMANCE TABLE

性能表 Performance Table (输入转速为3,000rpm时 When Input Speed Is 3000rpm)

额定输入 马达功率 Rated Input Motor	减速比 Reduction Ratio	系列号 Model				输出轴 转速 Outout Shaft Speed (rpm)	额定输出 扭矩 Standard Output Torque (N.m)	瞬间最大 输出扭矩 Instantaneous Max.Output Torque (N.m)	容许径向 负荷 Permissible Radial Load (N)	容许轴向 负荷 Permissible Axial Load (N)	输入轴换算 内部惯性力矩 Internal Moment Of Inertia Of Input Shaftconversion ($\times 10^{-4}$ kg.m ²)	容许输出 扭矩 Permissible Output Torque (N.m)	瞬间最大容 许输出扭矩 Instantaneous Max. Permissible Output Torque (N.m)
		机座号 Type No.	系列号 Model	减速比 Reduction Ratio	马达功率 Motor								
200W	1/3	52	ZDR	3	200	1000	1.47	4.51	392	196	0.135	3.43	10.3
	1/5	52	ZDR	5	200	600	2.65	8.04	490	245	0.118	2.84	8.53
	1/9	78	ZDR	9	200	333	3.72	11.3	1180	588	0.275	9.70	29.2
	1/15	78	ZDR	15	200	200	6.27	18.8	1470	735	0.300	16.2	48.6
	1/20	78	ZDR	20	200	150	8.69	26.1	1570	785	0.294	21.1	63.3
	1/25	78	ZDR	25	200	120	11.1	33.3	1670	833	0.288	21.7	64.9
	1/35	78	ZDR	35	200	85	15.5	46.6	1670	833	0.262	15.5	46.6
	1/45	98	ZDR	45	200	66	21.1	63.5	2060	1030	0.0256	28.3	85.2
	1/81	125	ZDR	81	200	37	36.1	108.3	3530	1765	0.240	43.3	129.9

注1) 安装基准系列(马达适用表记载系列)以外的马达时, 每次都是与我们联系。(法兰尺寸可能不同)

注2) 输入轴换算惯性力矩仅为减速机的数值, 不包括马达的惯性力矩。

注3) 最高输入转速为5000rpm。正常情况下请转速控制在3000rpm以下。

注4) 容许径向负荷表示输出轴中央部位的值。

注5) 全部为斜齿轮适用范围。

注6) 马达的安装顺序请参照P31。

注7) 输出轴旋转方向与马达输入旋转方向相同。

Note1) In case of attachment to a motor beyond the standard models(motor matching series), contact us. (How to measure dimensions of the flange may be changed in some cases.)

Note2) The moment of inertia of input shaft conversion is only gained from the reducer, so it does not include moment of inertia of the motor.

Note3) The max. input speed is 5000rpm, and usually set to 3000rpm or less.

Note4) The permissible radial load is indicated on the center of the output shaft.

Note5) All values are within the range corresponding to helical gear.

Note6) For motor assembly procedure, see page 31.

Note7) Rotation of the output shaft is in the same direction as motor.

尺寸表 Dimensions

● 52ZDR3-5-200

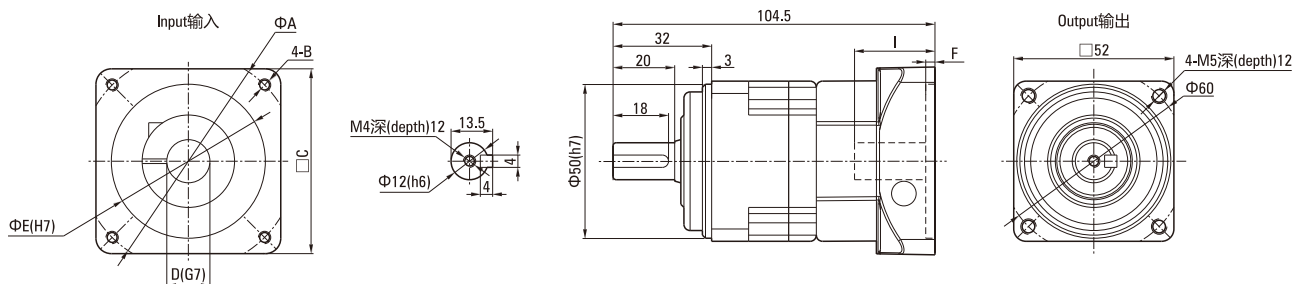

● 法兰部位详细尺寸表 Detailed Flange Dimensions Table

(单位Unit:mm)

马达种类 Motor Type	A	B	C	D	E	F	I
T1	70	M4深(depth)10	60	11	50	4	30
T2	70	M5深(depth)10	60	14	50	4	30
T3	70	M5深(depth)10	60	14	50	4	30

- 概略重量0.72kg
Rough weight 0.72kg
- T1~3的详细情况请参照P.43
For details of T1~3, see page 43

● 78ZDR9-200

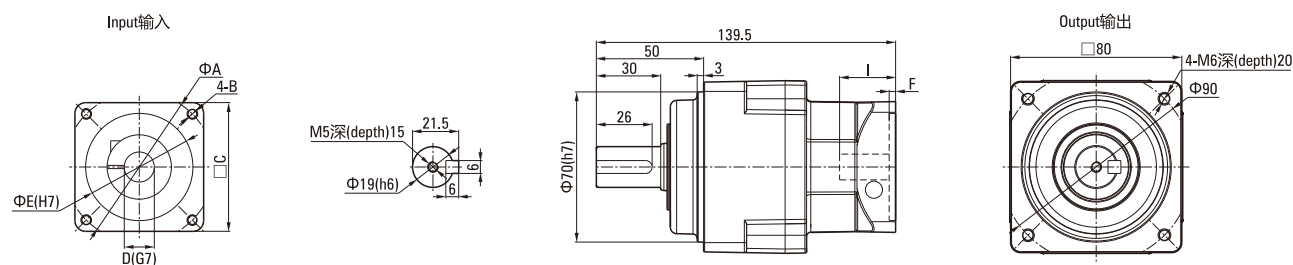

● 法兰部位详细尺寸表 Detailed Flange Dimensions Table

(单位Unit:mm)

马达种类 Motor Type	A	B	C	D	E	F	I
T1	70	M4深(depth)10	60	11	50	4	30
T2	70	M5深(depth)10	60	14	50	4	30
T3	70	M5深(depth)10	60	14	50	4	30

- 概略重量1.7kg
Rough weight 1.7kg
- T1~3的详细情况请参照P.43
For details of T1~3, see page 43

200W尺寸图与性能表

200W DIMENSIONAL DRAWING & PERFORMANCE TABLE

■ 尺寸表 Dimensions

● 78ZDR15-20-25-35-200

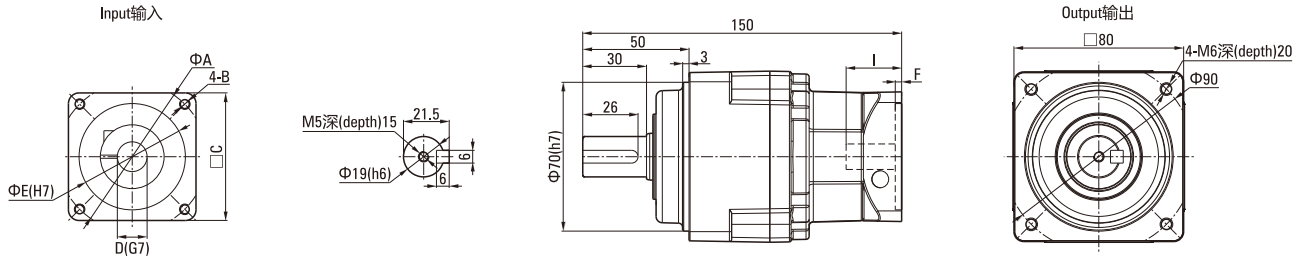

● 法兰部位详细尺寸表 Detailed Flange Dimensions Table

(单位Unit:mm)

马达种类 Motor Type	A	B	C	D	E	F	I
T1	70	M4深(depth)10	60	11	50	4	30
T2	70	M5深(depth)10	60	14	50	4	30
T3	70	M5深(depth)10	60	14	50	4	30

- 概略重量2.1kg
Rough weight 2.1kg
- T1~3的详细情况请参照P43
For details of T1~3, see page 43

● 98ZDR45-200

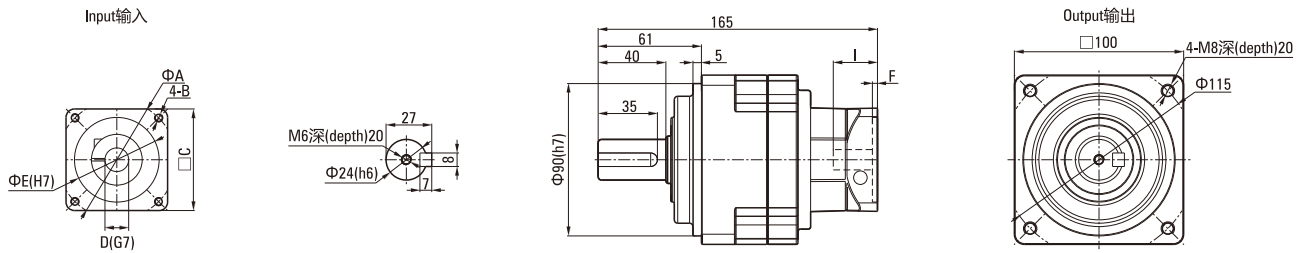

● 法兰部位详细尺寸表 Detailed Flange Dimensions Table

(单位Unit:mm)

马达种类 Motor Type	A	B	C	D	E	F	I
T1	70	M4深(depth)10	60	11	50	4	30
T2	70	M5深(depth)10	60	14	50	4	30
T3	70	M5深(depth)10	60	14	50	4	30

- 概略重量3.2kg
Rough weight 3.2kg
- T1~3的详细情况请参照P43
For details of T1~3, see page 43

● 125ZDR81-200

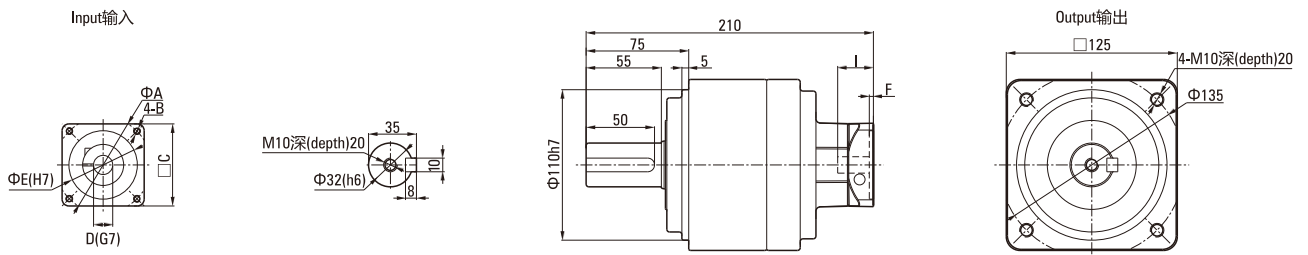

● 法兰部位详细尺寸表 Detailed Flange Dimensions Table

(单位Unit:mm)

马达种类 Motor Type	A	B	C	D	E	F	I
T1	70	M4深(depth)10	60	11	50	4	30
T2	70	M5深(depth)10	60	14	50	4	30
T3	70	M5深(depth)10	60	14	50	4	30

- 概略重量3.0kg
Rough weight 3.0kg
- T1~3的详细情况请参照P43
For details of T1~3, see page 43

400W尺寸图与性能表

400W DIMENSIONAL DRAWING & PERFORMANCE TABLE

性能表 Performance Table (输入转速为3,000rpm时 When Input Speed Is 3000rpm)

额定输入 马达功率 Rated Input Motor	减速比 Reduction Ratio	系列号 Model				输出轴 转速 Outout Shaft Speed (rpm)	额定输出 扭矩 Standard Output Torque (N.m)	瞬间最大 输出扭矩 Instantaneous Max.Output Torque (N.m)	容许径向 负荷 Permissible Radial Load (N)	容许轴向 负荷 Permissible Axial Load (N)	输入轴换算 内部惯性力矩 Internal Moment Of Inertia Of Input Shaftconversion ($\times 10^{-4}$ kg.m ²)	容许输出 扭矩 Permissible Output Torque (N.m)	瞬间最大容 许输出扭矩 Instantaneous Max. Permissible Output Torque (N.m)
		机座号 Type No.	系列号 Model	减速比 Reduction Ratio	马达功率 Motor								
400W	1/3	52	ZDR	3	400	1000	3.43	10.3	392	196	0.145	3.43	10.3
	1/5	78	ZDR	5	400	600	5.39	16.2	980	490	0.363	6.57	19.7
	1/9	78	ZDR	9	400	333	9.51	28.5	1180	588	0.275	9.70	29.2
	1/15	78	ZDR	15	400	200	15.8	47.5	1470	735	0.300	16.2	48.6
	1/20	78	ZDR	20	400	150	21.1	63.3	1570	785	0.294	21.1	63.3
	1/25	78	ZDR	25	400	120	26.4	79.2	1670	833	0.288	26.4	79.2
	1/35	98	ZDR	35	400	85	37.0	111	2060	1030	0.269	37.0	111
	1/45	125	ZDR	45	400	66	47.5	142.5	3520	1760	0.245	57	171

注1) 安装基准系列(马达适用表记载系列)以外的马达时, 每次都是与我们联系。(法兰尺寸可能不同)

注2) 输入轴换算惯性力矩仅为减速机的数值, 不包括马达的惯性力矩。

注3) 最高输入转速为5000rpm。正常情况下请转速控制在3000rpm以下。

注4) 容许径向负荷表示输出轴中央部位的值。

注5) 全部为斜齿轮适用范围。

注6) 马达的安装顺序请参照P.31。

注7) 输出轴旋转方向与马达输入旋转方向相同。

Note1) In case of attachment to a motor beyond the standard models(motor matching series), contact us. (How to measure dimensions of the flange may be changed in some cases.)

Note2) The moment of inertia of input shaft conversion is only gained from the reducer, so it does not include moment of inertia of the motor.

Note3) The max. input speed is 5000rpm, and usually set to 3000rpm or less.

Note4) The permissible radial load is indicated on the center of the output shaft.

Note5) All values are within the range corresponding to helical gear.

Note6) For motor assembly procedure, see page 31.

Note7) Rotation of the output shaft is in the same direction as motor.

尺寸表 Dimensions

● 52ZDR3-400

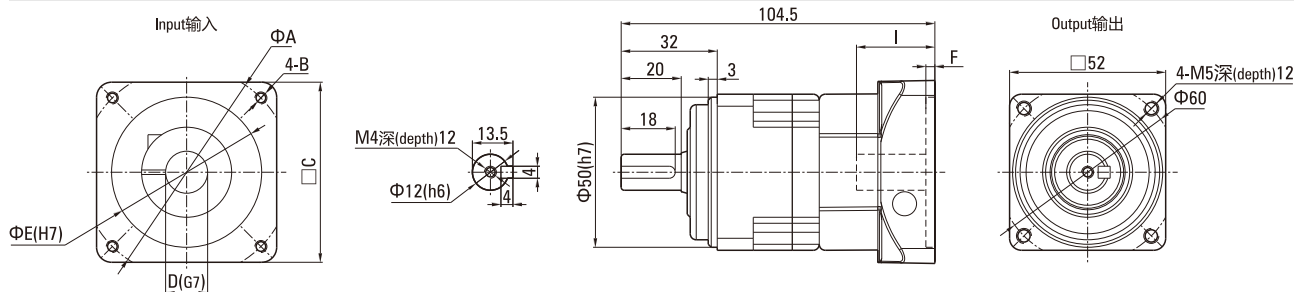

● 法兰部位详细尺寸表 Detailed Flange Dimensions Table

(单位Unit:mm)

马达种类 Motor Type	A	B	C	D	E	F	I
T1	70	M4深(depth)10	60	14	50	4	30
T2	70	M5深(depth)10	60	14	50	4	30
T3	70	M5深(depth)10	60	14	50	4	30

- 概略重量0.71kg
Rough weight 0.71kg
- T1~3的详细情况请参照P.43
For details of T1~3, see page 43

● 78ZDR5-9-400

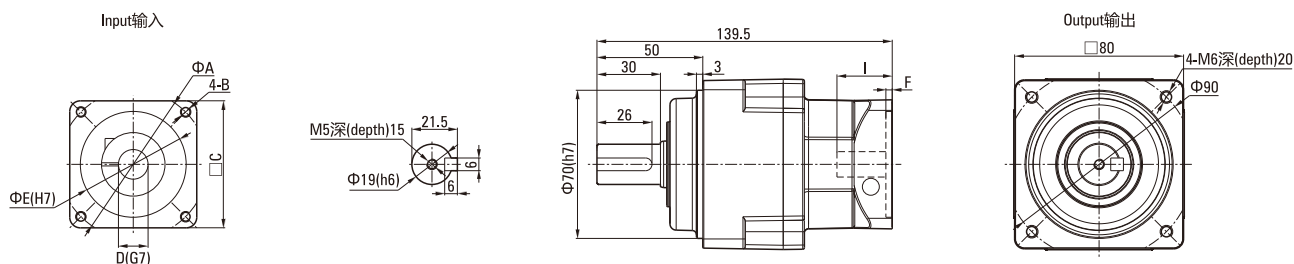

● 法兰部位详细尺寸表 Detailed Flange Dimensions Table

(单位Unit:mm)

马达种类 Motor Type	A	B	C	D	E	F	I
T1	70	M4深(depth)10	60	14	50	4	30
T2	70	M5深(depth)10	60	14	50	4	30
T3	70	M5深(depth)10	60	14	50	4	30

- 概略重量1.7kg
Rough weight 1.7kg
- T1~3的详细情况请参照P.43
For details of T1~3, see page 43

400W尺寸图与性能表

400W DIMENSIONAL DRAWING & PERFORMANCE TABLE

■ 尺寸表 Dimensions

● 78ZDR15-20-25-400

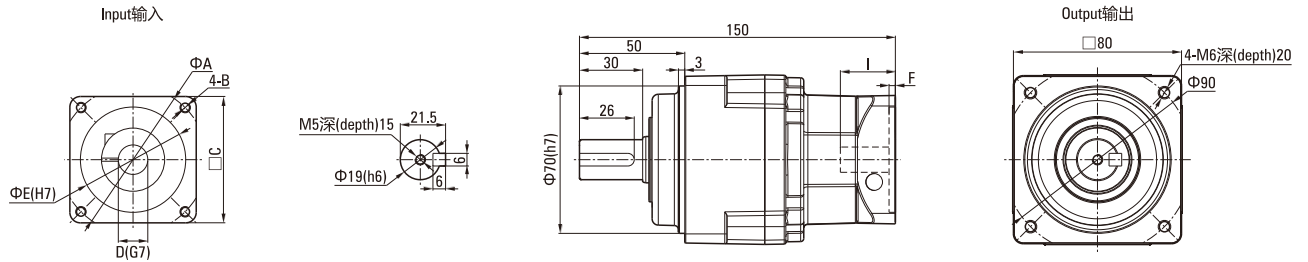

● 法兰部位详细尺寸表 Detailed Flange Dimensions Table

(单位Unit:mm)

马达种类 Motor Type	A	B	C	D	E	F	I
T1	70	M4深(depth)10	60	14	50	4	30
T2	70	M5深(depth)10	60	14	50	4	30
T3	70	M5深(depth)10	60	14	50	4	30

- 概略重量2.1kg
Rough weight 2.1kg
- T1~3的详细情况请参照P43
For details of T1~3, see page 43

● 98ZDR35-400

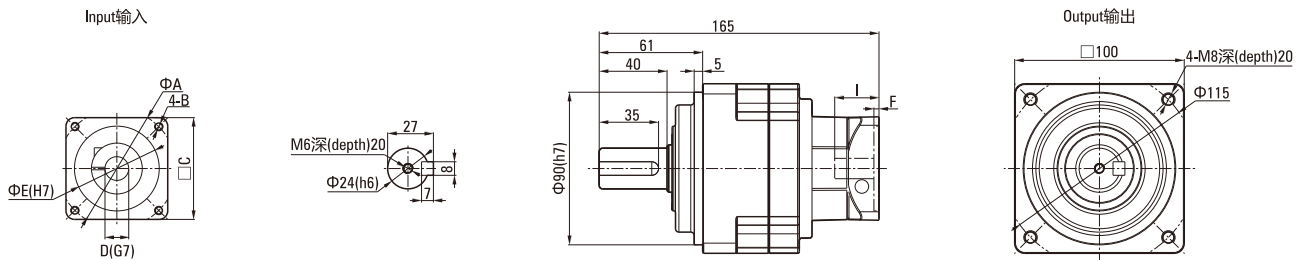

● 法兰部位详细尺寸表 Detailed Flange Dimensions Table

(单位Unit:mm)

马达种类 Motor Type	A	B	C	D	E	F	I
T1	70	M4深(depth)10	60	14	50	4	30
T2	70	M5深(depth)10	60	14	50	4	30
T3	70	M5深(depth)10	60	14	50	4	30

- 概略重量3.2kg
Rough weight 3.2kg
- T1~3的详细情况请参照P43
For details of T1~3, see page 43

● 125ZDR45-400

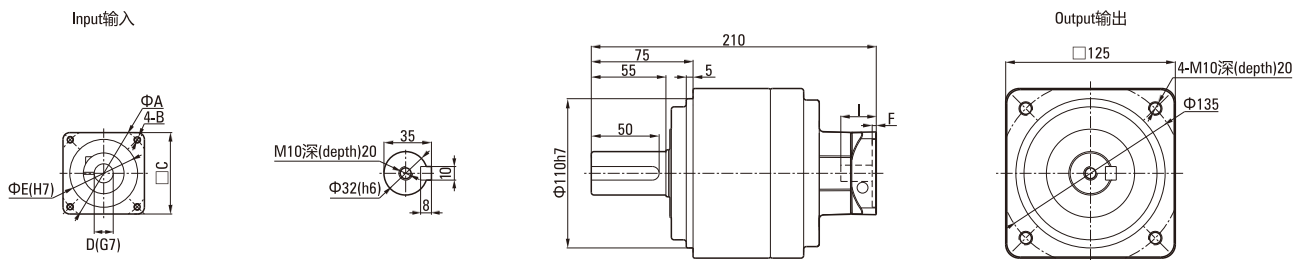

● 法兰部位详细尺寸表 Detailed Flange Dimensions Table

(单位Unit:mm)

马达种类 Motor Type	A	B	C	D	E	F	I
T1	70	M4深(depth)10	60	14	50	4	30
T2	70	M5深(depth)10	60	14	50	4	30
T3	70	M5深(depth)10	60	14	50	4	30

- 概略重量7.2kg
Rough weight 7.2kg
- T1~3的详细情况请参照P43
For details of T1~3, see page 43

750W尺寸图与性能表

750W DIMENSIONAL DRAWING & PERFORMANCE TABLE

性能表 Performance Table (输入转速为3,000rpm时 When Input Speed Is 3000rpm)

额定输入 马达功率 Rated Input Motor	减速比 Reduction Ratio	系列号 Model				输出轴 转速 Outout Shaft Speed (rpm)	额定输出 扭矩 Standard Output Torque (N.m)	瞬间最大 输出扭矩 Instantaneous Max.Output Torque (N.m)	容许径向 负荷 Permissible Radial Load (N)	容许轴向 负荷 Permissible Axial Load (N)	输入轴换算 内部惯性力矩 Internal Moment Of Inertia Of Input Shaftconversion ($\times 10^{-4}$ kg.m ²)	容许输出 扭矩 Permissible Output Torque (N.m)	瞬间最大容 许输出扭矩 Instantaneous Max. Permissible Output Torque (N.m)
		机座号 Type No.	系列号 Model	减速比 Reduction Ratio	马达功率 Motor								
750W	1/3	78	ZDR	3	750	1000	6.37	19.3	784	392	0.913	6.86	20.6
	1/5	78	ZDR	5	750	600	10.7	32.1	980	490	0.713	11.5	34.3
	1/9	98	ZDR	9	750	333	18.2	54.7	1470	735	0.650	18.2	54.7
	1/15	98	ZDR	15	750	200	30.4	91.2	1760	882	0.700	30.4	91.2
	1/20	98	ZDR	20	750	150	40.6	122	1910	955	0.690	40.6	122
	1/25	98	ZDR	25	750	120	50.7	152	2060	1030	0.680	50.7	152
	1/35	125	ZDR	35	750	85	71.0	213	3430	1715	0.473	71.0	213
	1/45	125	ZDR	45	750	66	91.3	274	3520	1760	1.77	91.3	274

注1) 安装基准系列(马达适用表记载系列)以外的马达时, 每次都是与我们联系。(法兰尺寸可能不同)

注2) 输入轴换算惯性力矩仅为减速机的数值, 不包括马达的惯性力矩。

注3) 最高输入转速为5000rpm。正常情况下请转速控制在3000rpm以下。

注4) 容许径向负荷表示输出轴中央部位的值。

注5) 全部为斜齿轮适用范围。

注6) 马达的安装顺序请参照P.31。

注7) 输出轴旋转方向与马达输入旋转方向相同。

Note1) In case of attachment to a motor beyond the standard models(motor matching series), contact us. (How to measure dimensions of the flange may be changed in some cases.)

Note2) The moment of inertia of input shaft conversion is only gained from the reducer, so it does not include moment of inertia of the motor.

Note3) The max. input speed is 5000rpm, and usually set to 3000rpm or less.

Note4) The permissible radial load is indicated on the center of the output shaft.

Note5) All values are within the range corresponding to helical gear.

Note6) For motor assembly procedure, see page 31.

Note7) Rotation of the output shaft is in the same direction as motor.

尺寸表 Dimensions

● 78ZDR3-5-750

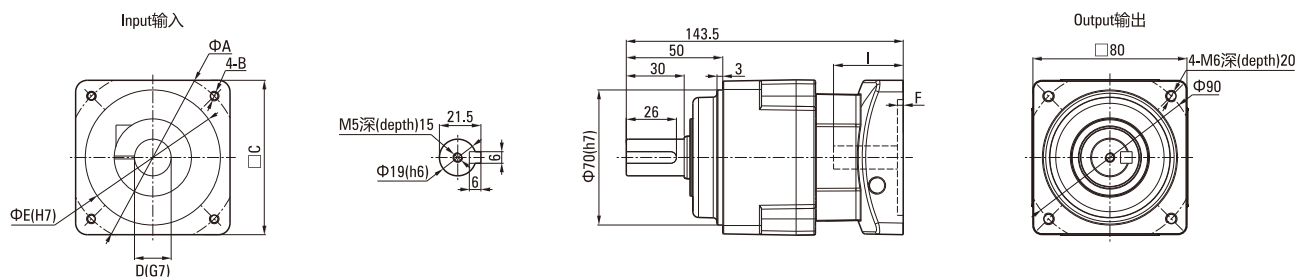

● 法兰部位详细尺寸表 Detailed Flange Dimensions Table

(单位Unit:mm)

马达种类 Motor Type	A	B	C	D	E	F	I
T1	90	M5深(depth)10	80	19	70	4	40
T2	90	M6深(depth)10	80	16	70	4	40
T3	90	M6深(depth)10	80	19	70	4	40

- 概略重量2.1kg
Rough weight 2.1kg
- T1~3的详细情况请参照P.43
For details of T1~3, see page 43

● 98ZDR9-750

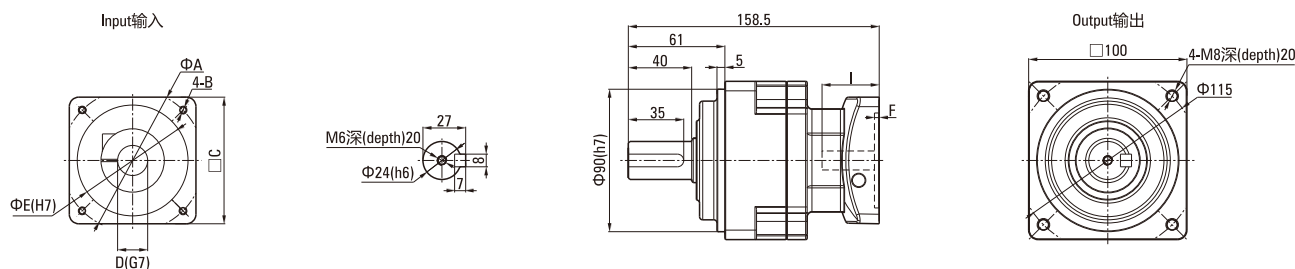

● 法兰部位详细尺寸表 Detailed Flange Dimensions Table

(单位Unit:mm)

马达种类 Motor Type	A	B	C	D	E	F	I
T1	90	M5深(depth)10	80	19	70	4	40
T2	90	M6深(depth)10	80	16	70	4	40
T3	90	M6深(depth)10	80	19	70	4	40

- 概略重量3.4kg
Rough weight 3.4kg
- T1~3的详细情况请参照P.43
For details of T1~3, see page 43

750W尺寸图与性能表

750W DIMENSIONAL DRAWING & PERFORMANCE TABLE

尺寸表 Dimensions

● 98ZDR15-20-25-750

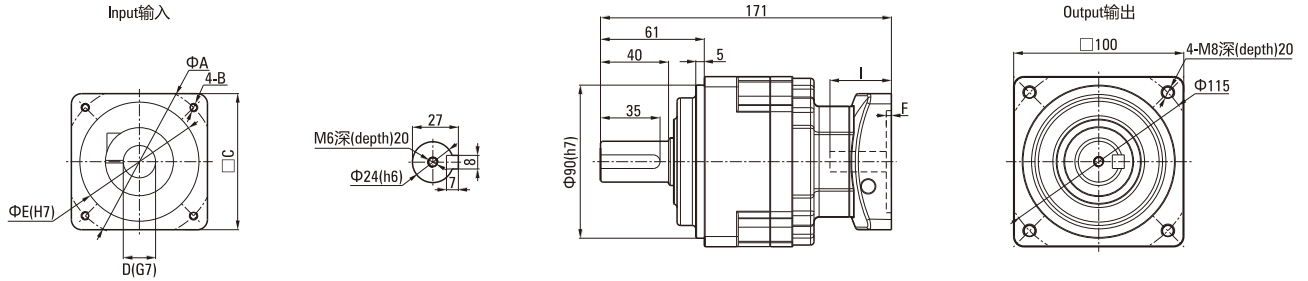

● 法兰部位详细尺寸表 Detailed Flange Dimensions Table

(单位Unit:mm)

马达种类 Motor Type	A	B	C	D	E	F	I
T1	90	M5深(depth)10	80	19	70	4	40
T2	90	M6深(depth)10	80	16	70	4	40
T3	90	M6深(depth)10	80	19	70	4	40

● 概略重量3.8kg

Rough weight 3.8kg

● T1~3的详细情况请参照P43

For details of T1~3, see page 43

● 125ZDR35-750

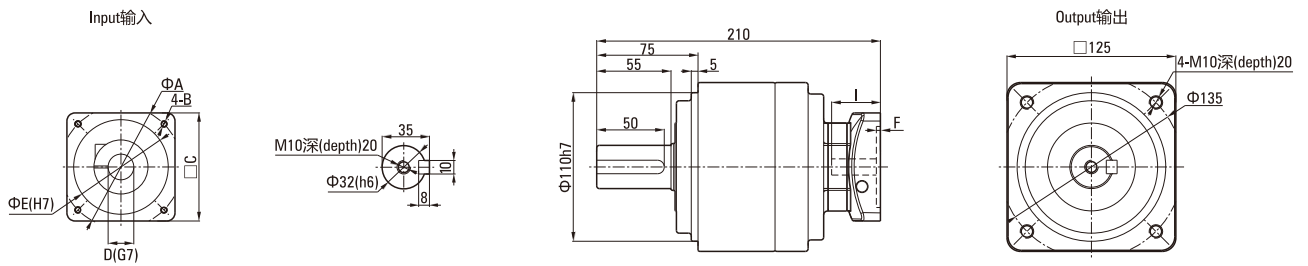

● 法兰部位详细尺寸表 Detailed Flange Dimensions Table

(单位Unit:mm)

马达种类 Motor Type	A	B	C	D	E	F	I
T1	90	M5深(depth)10	80	19	70	4	40
T2	90	M6深(depth)10	80	16	70	4	40
T3	90	M6深(depth)10	80	19	70	4	40

● 概略重量7.2kg

Rough weight 7.2kg

● T1~3的详细情况请参照P43

For details of T1~3, see page 43

● 125ZDR45-750

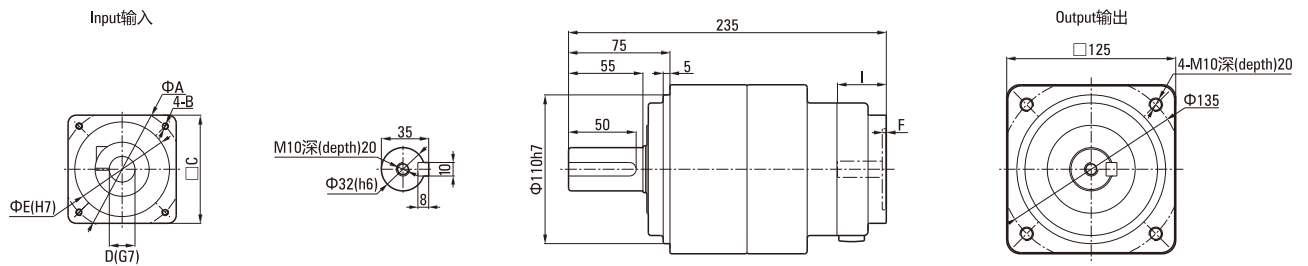

● 法兰部位详细尺寸表 Detailed Flange Dimensions Table

(单位Unit:mm)

马达种类 Motor Type	A	B	C	D	E	F	I
T1	90	M5深(depth)10	80	19	70	4	40
T2	90	M6深(depth)10	80	16	70	4	40
T3	90	M6深(depth)10	80	19	70	4	40

● 概略重量12.0kg

Rough weight 12.0kg

● T1~3的详细情况请参照P43

For details of T1~3, see page 43

1000W尺寸图与性能表

1000W DIMENSIONAL DRAWING & PERFORMANCE TABLE

性能表 Performance Table (输入转速为3,000rpm时 When Input Speed Is 3000rpm)

额定输入 马达功率 Rated Input Motor	减速比 Reduction Ratio	系列号 Model				输出轴 转速 Outout Shaft Speed (rpm)	额定输出 扭矩 Standard Output Torque (N.m)	瞬间最大 输出扭矩 Instantaneous Max.Output Torque (N.m)	容许径向 负荷 Permissible Radial Load (N)	容许轴向 负荷 Permissible Axial Load (N)	输入轴换算 内部惯性力矩 Of Input Shaftconversion Internal Moment Ofinertia (x10 ⁻⁴ kg.m ²)	容许输出 扭矩 Permissible Output Torque (N.m)	瞬间最大容 许输出扭矩 Instantaneous Max. Permissible Output Torque (N.m)
		机座号 Type No.	系列号 Model	减速比 Reduction Ratio	马达功率 Motor								
1000W	1/3	98	ZDR	3	1000	1000	7.55	22.8	882	441	2.43	18.3	54.9
	1/5	98	ZDR	5	1000	600	13.4	40.5	1080	539	1.85	23.5	70.6
	1/9	125	ZDR	9	1000	333	20.2	60.1	1960	980	2.81	73.5	221
	1/15	125	ZDR	15	1000	200	33.3	100	2350	1180	1.95	91.4	274
	1/25	125	ZDR	25	1000	120	55.7	167	2650	1320	1.88	65.4	196

注1) 安装基准系列(马达适用表记载系列)以外的马达时, 每次都是与我们联系。(法兰尺寸可能不同)

注2) 输入轴换算惯性力矩仅为减速机的数值, 不包括马达的惯性力矩。

注3) 最高输入转速为5000rpm。正常情况下请转速控制在3000rpm以下。

注4) 容许径向负荷表示输出轴中央部位的值。

注5) 全部为斜齿轮适用范围。

注6) 马达的安装顺序请参照P31。

注7) 输出轴旋转方向与马达输入旋转方向相同。

Note1) In case of attachment to a motor beyond the standard models(motor matching series), contact us. (How to measure dimensions of the flange may be changed in some cases.)

Note2) The moment of inertia of input shaft conversion is only gained from the reducer, so it does not include moment of inertia of the motor.

Note3) The max. input speed is 5000rpm, and usually set to 3000rpm or less.

Note4) The permissible radial load is indicated on the center of the output shaft.

Note5) All values are within the range corresponding to helical gear.

Note6) For motor assembly procedure, see page 31.

Note7) Rotation of the output shaft is in the same direction as motor.

尺寸表 Dimensions

● 98ZDR3-5-1000

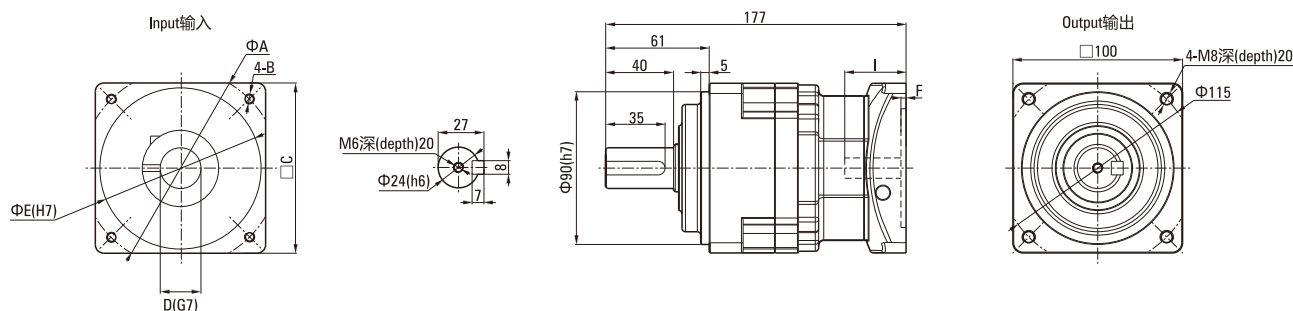

● 法兰部位详细尺寸表 Detailed Flange Dimensions Table

(单位Unit:mm)

马达种类 Motor Type	A	B	C	D	E	F	I
T1	100	M6深(depth)15	90	19	80	4	55
T2	115	M6深(depth)15	100	24	95	4	55
T3	115	M8深(depth)15	100	24	95	4	55

● 概略重量3.9kg

Rough weight 3.9kg

● T1~3的详细情况请参照P.43

For details of T1~3, see page 43

1000W尺寸图与性能表

1000W DIMENSIONAL DRAWING & PERFORMANCE TABLE

尺寸表 Dimensions

● 125ZDR9-1000

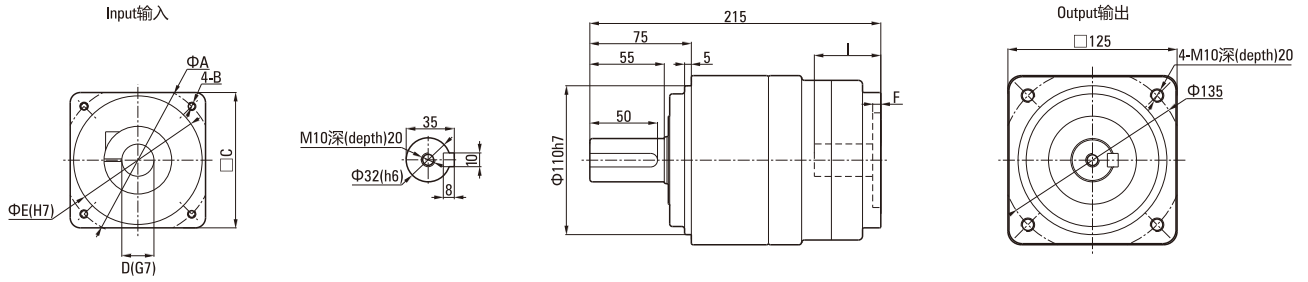

● 法兰部位详细尺寸表 Detailed Flange Dimensions Table

(单位Unit:mm)

马达种类 Motor Type	A	B	C	D	E	F	I
T1	100	M6深(depth)15	90	19	80	4	55
T2	115	M6深(depth)15	100	24	95	4	55
T3	115	M8深(depth)15	100	24	95	4	55

• 概略重量11.0kg

Rough weight 11.0kg

• T1~3的详细情况请参照P43

For details of T1~3, see page 43

● 125ZDR15-25-1000

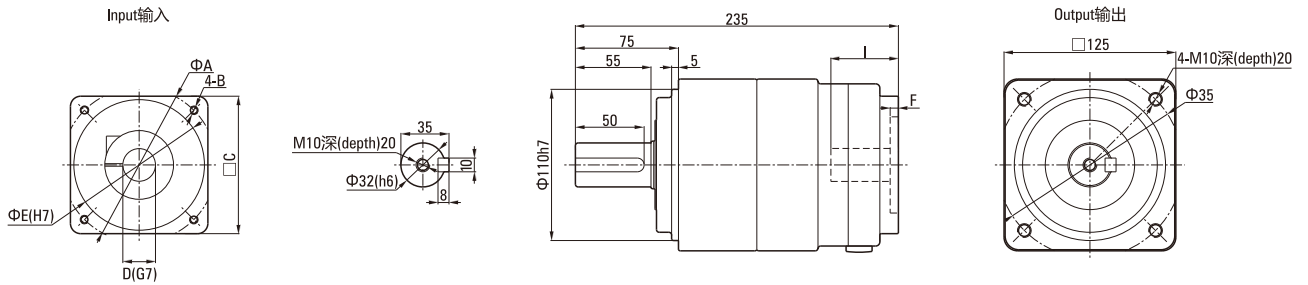

● 法兰部位详细尺寸表 Detailed Flange Dimensions Table

(单位Unit:mm)

马达种类 Motor Type	A	B	C	D	E	F	I
T1	100	M6深(depth)15	90	19	80	4	55
T2	115	M6深(depth)15	100	24	95	4	55
T3	115	M8深(depth)15	100	24	95	4	55

• 概略重量12.0kg

Rough weight 12.0kg

• T1~3的详细情况请参照P43

For details of T1~3, see page 43

1500W尺寸图与性能表

1500W DIMENSIONAL DRAWING & PERFORMANCE TABLE

性能表 Performance Table (输入转速为3,000rpm时 When Input Speed Is 3000rpm)

额定输入 马达功率 Rated Input Motor	减速比 Reduction Ratio	系列号 Model				输出轴 转速 Outout Shaft Speed (rpm)	额定输出 扭矩 Standard Output Torque (N.m)	瞬间最大 输出扭矩 Instantaneous Max.Output Torque (N.m)	容许径向 负荷 Permissible Radial Load (N)	容许轴向 负荷 Permissible Axial Load (N)	输入轴换算 内部惯性力矩 Of Input Shaftconversion (x10 ⁻⁴ kg.m ²)	容许输出 扭矩 Permissible Output Torque (N.m)	瞬间最大容 许输出扭矩 Instantaneous Max. Permissible Output Torque (N.m)
		机座号 Type No.	系列号 Model	减速比 Reduction Ratio	马达功率 Motor								
1500W	1/3	98	ZDR	3	1500	1000	12.3	37.1	882	441	2.43	18.3	54.9
	1/5	98	ZDR	5	1500	600	21.5	64.4	1080	539	1.85	23.5	70.6
	1/9	125	ZDR	9	1500	333	34.3	103	1960	980	2.81	73.5	221
	1/15	125	ZDR	15	1500	200	57.2	172	2350	1180	2.80	91.4	274

注1) 安装基准系列(马达适用表记载系列)以外的马达时, 每次都是与我们联系。(法兰尺寸可能不同)

注2) 输入轴换算惯性力矩仅为减速机的数值, 不包括马达的惯性力矩。

注3) 最高输入转速为5000rpm。正常情况下请转速控制在3000rpm以下。

注4) 容许径向负荷表示输出轴中央部位的值。

注5) 全部为斜齿轮适用范围。

注6) 马达的安装顺序请参照P31。

注7) 输出轴旋转方向与马达输入旋转方向相同。

Note1) In case of attachment to a motor beyond the standard models(motor matching series), contact us. (How to measure dimensions of the flange may be changed in some cases.)

Note2) The moment of inertia of input shaft conversion is only gained from the reducer, so it does not include moment of inertia of the motor.

Note3) The max. input speed is 5000rpm, and usually set to 3000rpm or less.

Note4) The permissible radial load is indicated on the center of the output shaft.

Note5) All values are within the range corresponding to helical gear.

Note6) For motor assembly procedure, see page 31.

Note7) Rotation of the output shaft is in the same direction as motor.

尺寸表 Dimensions

● 98ZDR3-5-1500

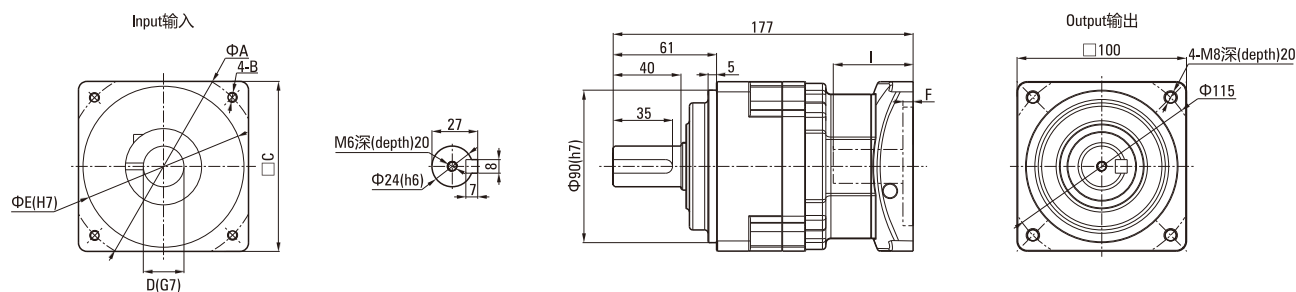

● 法兰部位详细尺寸表 Detailed Flange Dimensions Table

(单位Unit:mm)

马达种类 Motor Type	A	B	C	D	E	F	I
T1	115	M8深(depth)15	100	19	95	4	55
T2	115	M6深(depth)15	100	24	95	4	55
T3	115	M8深(depth)15	100	24	95	4	55

● 概略重量3.9kg

Rough weight 3.9kg

● T1~3的详细情况请参照P.43

For details of T1~3, see page 43

1500W 尺寸图与性能表

1500W DIMENSIONAL DRAWING & PERFORMANCE TABLE

■ 尺寸表 Dimensions

● 125ZDR9-1500

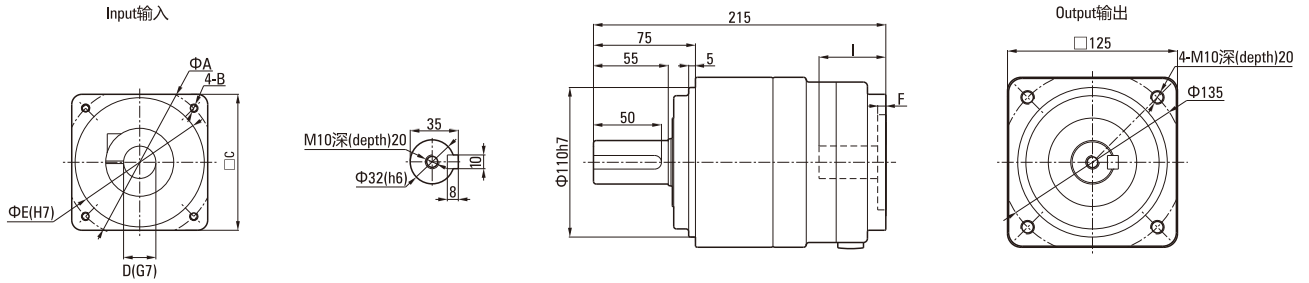

● 法兰部位详细尺寸表 Detailed Flange Dimensions Table

(单位Unit:mm)

马达种类 Motor Type	A	B	C	D	E	F	I
T1	115	M8深(depth)15	100	19	95	4	55
T2	115	M6深(depth)15	100	24	95	4	55
T3	115	M8深(depth)15	100	24	95	4	55

• 概略重量11.5kg

Rough weight 11.5kg

• T1~3的详细情况请参照P43

For details of T1~3, see page 43

● 125ZDR15-1500

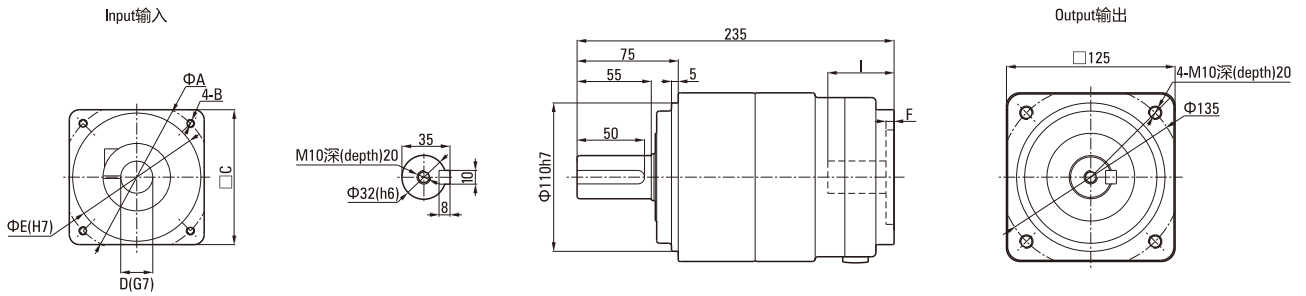

● 法兰部位详细尺寸表 Detailed Flange Dimensions Table

(单位Unit:mm)

马达种类 Motor Type	A	B	C	D	E	F	I
T1	115	M8深(depth)15	100	19	95	4	55
T2	115	M6深(depth)15	100	24	95	4	55
T3	115	M8深(depth)15	100	24	95	4	55

• 概略重量12.5kg

Rough weight 12.5kg

• T1~3的详细情况请参照P43

For details of T1~3, see page 43

2000W尺寸图与性能表

2000W DIMENSIONAL DRAWING & PERFORMANCE TABLE

性能表 Performance Table (输入转速为3,000rpm时 When Input Speed Is 3000rpm)

额定输入 马达功率 Rated Input Motor	减速比 Reduction Ratio	系列号 Model				输出轴 转速 Outout Shaft Speed (rpm)	额定输出 扭矩 Standard Output Torque (N.m)	瞬间最大 输出扭矩 Instantaneous Max.Output Torque (N.m)	容许径向 负荷 Permissible Radial Load (N)	容许轴向 负荷 Permissible Axial Load (N)	输入轴换算 内部惯性力矩 Of Input Shaftconversion ($\times 10^{-4}$ kg.m ²)	容许输出 扭矩 Permissible Output Torque (N.m)	瞬间最大容 许输出扭矩 Instantaneous Max. Permissible Output Torque (N.m)
		机座号 Type No.	系列号 Model	减速比 Reduction Ratio	马达功率 Motor								
2000W	1/3	98	ZDR	3	2000	1000	17.2	51.5	882	441	2.43	18.3	54.9
	1/5	125	ZDR	5	2000	600	23.8	71.5	1670	833	3.50	56.8	171
	1/9	125	ZDR	9	2000	333	48.6	146	1960	980	2.81	73.5	221
	1/15	125	ZDR	15	2000	200	81.0	243	2350	1180	2.80	91.4	274

注1) 安装基准系列(马达适用表记载系列)以外的马达时, 每次都是与我们联系。(法兰尺寸可能不同)

注2) 输入轴换算惯性力矩仅为减速机的数值, 不包括马达的惯性力矩。

注3) 最高输入转速为5000rpm。正常情况下请转速控制在3000rpm以下。

注4) 容许径向负荷表示输出轴中央部位的值。

注5) 全部为斜齿轮适用范围。

注6) 马达的安装顺序请参照P31。

注7) 输出轴旋转方向与马达输入旋转方向相同。

Note1) In case of attachment to a motor beyond the standard models(motor matching series), contact us. (How to measure dimensions of the flange may be changed in some cases.)

Note2) The moment of inertia of input shaft conversion is only gained from the reducer, so it does not include moment of inertia of the motor.

Note3) The max. input speed is 5000rpm, and usually set to 3000rpm or less.

Note4) The permissible radial load is indicated on the center of the output shaft.

Note5) All values are within the range corresponding to helical gear.

Note6) For motor assembly procedure, see page 31.

Note7) Rotation of the output shaft is in the same direction as motor.

尺寸表 Dimensions

● 98ZDR3-2000

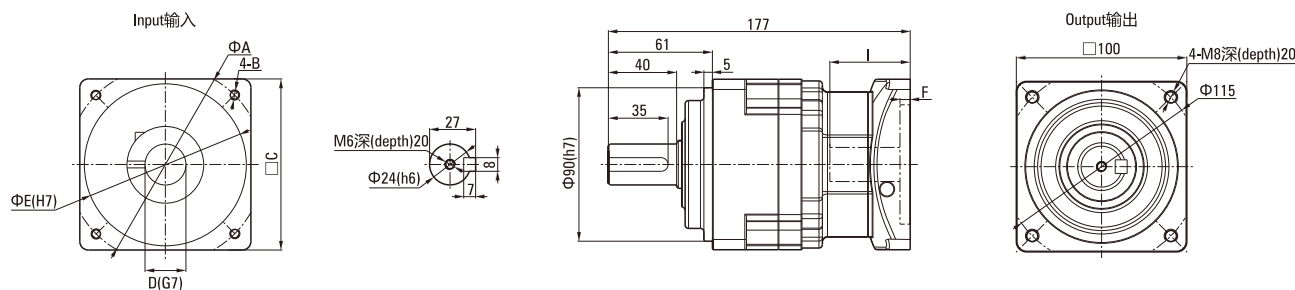

● 法兰部位详细尺寸表 Detailed Flange Dimensions Table

(单位Unit:mm)

马达种类 Motor Type	A	B	C	D	E	F	I
T1	115	M8深(depth)15	100	19	95	4	55
T2	115	M6深(depth)15	100	24	95	4	55
T3	115	M8深(depth)15	100	24	95	4	55

• 概略重量3.9kg

Rough weight 3.9kg

• T1~3的详细情况请参照P.43

For details of T1~3, see page 43

2000W 尺寸图与性能表

2000W DIMENSIONAL DRAWING & PERFORMANCE TABLE

■ 尺寸表 Dimensions

● 125ZDR5-9-2000

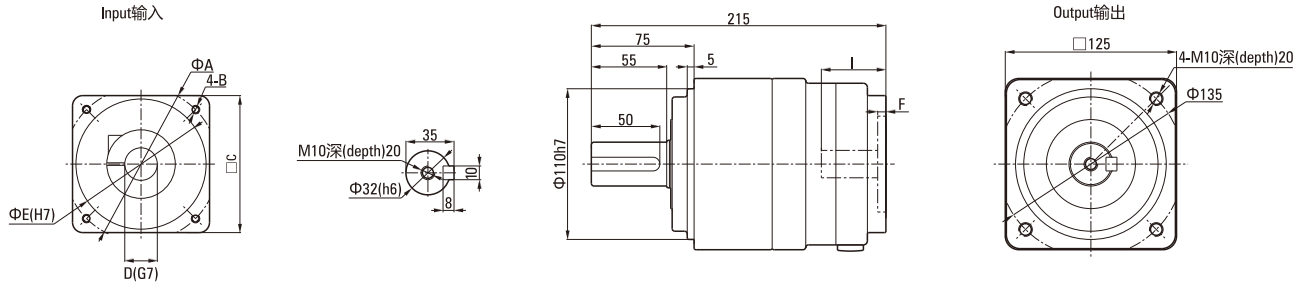

● 法兰部位详细尺寸表 Detailed Flange Dimensions Table

(单位Unit:mm)

马达种类 Motor Type	A	B	C	D	E	F	I
T1	115	M8深(depth)15	100	19	95	4	55
T2	115	M6深(depth)15	100	24	95	4	55
T3	115	M8深(depth)15	100	24	95	4	55

• 概略重量11.5kg

Rough weight 11.5kg

• T1~3的详细情况请参照P43

For details of T1~3, see page 43

● 125ZDR15-2000

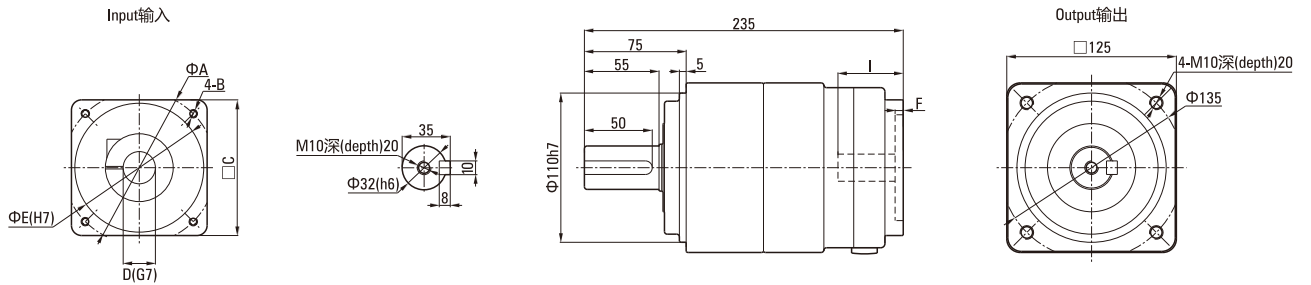

● 法兰部位详细尺寸表 Detailed Flange Dimensions Table

(单位Unit:mm)

马达种类 Motor Type	A	B	C	D	E	F	I
T1	115	M8深(depth)15	100	19	95	4	55
T2	115	M6深(depth)15	100	24	95	4	55
T3	115	M8深(depth)15	100	24	95	4	55

• 概略重量12.5kg

Rough weight 12.5kg

• T1~3的详细情况请参照P43

For details of T1~3, see page 43

2500W尺寸图与性能表

2500W DIMENSIONAL DRAWING & PERFORMANCE TABLE

性能表 Performance Table (输入转速为3,000rpm时 When Input Speed Is 3000rpm)

额定输入 马达功率 Rated Input Motor	减速比 Reduction Ratio	系列号 Model				输出轴 转速 Outout Shaft Speed (rpm)	额定输出 扭矩 Standard Output Torque (N.m)	瞬间最大 输出扭矩 Instantaneous Max.Output Torque (N.m)	容许径向 负荷 Permissible Radial Load (N)	容许轴向 负荷 Permissible Axial Load (N)	输入轴换算 内部惯性力矩 Of Input Shaftconversion (x10 ⁻⁴ kg.m ²)	容许输出 扭矩 Permissible Output Torque (N.m)	瞬间最大容 许输出扭矩 Instantaneous Max. Permissible Output Torque (N.m)
		机座号 Type No.	系列号 Model	减速比 Reduction Ratio	马达功率 Motor								
2500W	1/3	125	ZDR	3	2500	1000	19.0	57.2	1370	686	5.55	44.1	132
	1/5	125	ZDR	5	2500	600	31.8	95.5	1670	833	3.50	56.8	171
	1/9	125	ZDR	9	2500	333	60.8	182	1960	980	2.81	73.5	221

注1) 安装基准系列(马达适用表记载系列)以外的马达时,每次都是与我们联系。(法兰尺寸可能不同)

注2) 输入轴换算惯性力矩仅为减速机的数值,不包括马达的惯性力矩。

注3) 最高输入转速为5000rpm。正常情况下请转速控制在3000rpm以下。

注4) 容许径向负荷表示输出轴中央部位的值。

注5) 全部为斜齿轮适用范围。

注6) 马达的安装顺序请参照P.31。

注7) 输出轴旋转方向与马达输入旋转方向相同。

Note1) In case of attachment to a motor beyond the standard models (motor matching series), contact us. (How to measure dimensions of the flange may be changed in some cases.)

Note2) The moment of inertia of input shaft conversion is only gained from the reducer, so it does not include moment of inertia of the motor.

Note3) The max. input speed is 5000rpm, and usually set to 3000rpm or less.

Note4) The permissible radial load is indicated on the center of the output shaft.

Note5) All values are within the range corresponding to helical gear.

Note6) For motor assembly procedure, see page 31.

Note7) Rotation of the output shaft is in the same direction as motor.

尺寸表 Dimensions

● 125ZDR3-5-9-2500

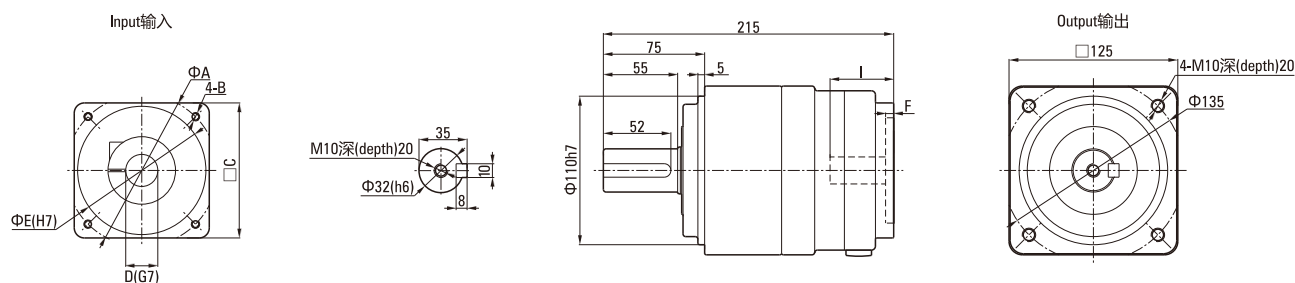

● 法兰部位详细尺寸表 Detailed Flange Dimensions Table

(单位Unit:mm)

马达种类 Motor Type	A	B	C	D	E	F	I
T1	115	M8深(depth)15	100	19	95	4	55
T2	115	M6深(depth)15	100	24	95	4	55
T3	-	-	-	-	-	-	-

● 概略重量11.5kg

Rough weight 11.5kg

● T1~3的详细情况请参照P.43

For details of T1~3, see page 43

3000W尺寸图与性能表

3000W DIMENSIONAL DRAWING & PERFORMANCE TABLE

■ 性能表 Performance Table (输入转速为3,000rpm时 When Input Speed Is 3000rpm)

额定输入 马达功率 Rated Input Motor	减速比 Reduction Ratio	系列号 Model				输出轴 转速 Outout Shaft Speed (rpm)	额定输出 扭矩 Standard Output Torque (N.m)	瞬间最大 输出扭矩 Instantaneous Max.Output Torque (N.m)	容许径向 负荷 Permissible Radial Load (N)	容许轴向 负荷 Permissible Axial Load (N)	输入轴换算 内部惯性力矩 Internal Moment Of inertia Of Input Shaftconversion ($\times 10^{-4}$ kg.m ²)	容许输出 扭矩 Permissible Output Torque (N.m)	瞬间最大容 许输出扭矩 Instantaneous Max. Permissible Output Torque (N.m)
		机座号 Type No.	系列号 Model	减速比 Reduction Ratio	马达功率 Motor								
3000W	1/3	125	ZDR	3	3000	1000	23.7	71.2	1370	686	5.50	44.1	132
	1/5	125	ZDR	5	3000	600	39.6	119	1670	833	3.48	56.8	171
	1/9	125	ZDR	9	3000	333	73.0	219	1960	980	2.77	73.5	221

注1) 安装基准系列(马达适用表记载系列)以外的马达时, 每次都是与我们联系。(法兰尺寸可能不同)

注2) 输入轴换算惯性力矩仅为减速机的数值, 不包括马达的惯性力矩。

注3) 最高输入转速为5000rpm。正常情况下请转速控制在3000rpm以下。

注4) 容许径向负荷表示输出轴中央部位的值。

注5) 全部为斜齿轮适用范围。

注6) 马达的安装顺序请参照P31。

注7) 输出轴旋转方向与马达输入旋转方向相同。

Note1) In case of attachment to a motor beyond the standard models (motor matching series), contact us. (How to measure dimensions of the flange may be changed in some cases.)

Note2) The moment of inertia of input shaft conversion is only gained from the reducer, so it does not include moment of inertia of the motor.

Note3) The max. input speed is 5000rpm, and usually set to 3000rpm or less.

Note4) The permissible radial load is indicated on the center of the output shaft.

Note5) All values are within the range corresponding to helical gear.

Note6) For motor assembly procedure, see page 31.

Note7) Rotation of the output shaft is in the same direction as motor.

■ 尺寸表 Dimensions

● 125ZDR3-5-9-3000

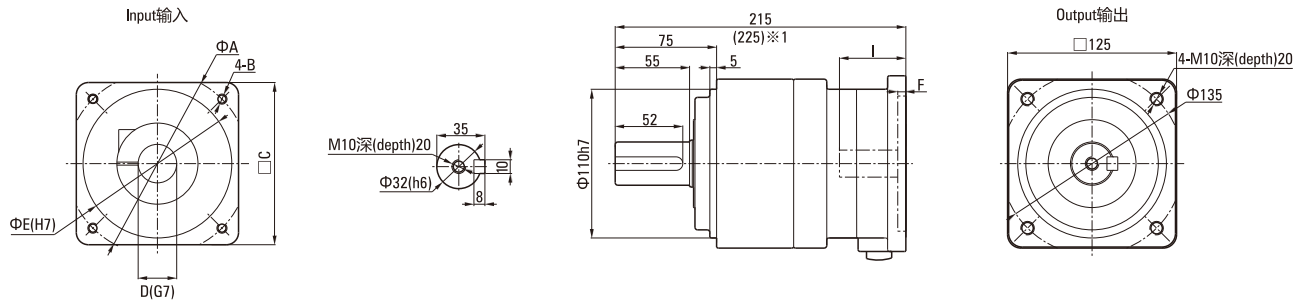

● 法兰部位详细尺寸表 Detailed Flange Dimensions Table

(单位Unit:mm)

马达种类 Motor Type	A	B	C	D	E	F	I
T1	130	M8深(depth)15	120	22	110	7	55
T2	145	M8深(depth)15	130	28	110	7	65
T3	-	-	-	-	-	-	-

• 概略重量12.0kg

Rough weight 12.0kg

• T1~3的详细情况请参照P43

For details of T1~3, see page 43

3500W尺寸图与性能表

3500W DIMENSIONAL DRAWING & PERFORMANCE TABLE

性能表 Performance Table (输入转速为3,000rpm时 When Input Speed Is 3000rpm)

额定输入 马达功率 Rated Input Motor	减速比 Reduction Ratio	系列号 Model				输出轴 转速 Outout Shaft Speed (rpm)	额定输出 扭矩 Standard Output Torque (N.m)	瞬间最大 输出扭矩 Instantaneous Max.Output Torque (N.m)	容许径向 负荷 Permissible Radial Load (N)	容许轴向 负荷 Permissible Axial Load (N)	输入轴换算 内部惯性力矩 Of Input Shaftconversion (x10 ⁻⁴ kg.m ²)	容许输出 扭矩 Permissible Output Torque (N.m)	瞬间最大容 许输出扭矩 Instantaneous Max. Permissible Output Torque (N.m)
		机座号 Type No.	系列号 Model	减速比 Reduction Ratio	马达功率 Motor								
3500W	1/3	125	ZDR	3	3500	1000	28.3	85.2	1370	686	5.50	44.1	132
	1/5	125	ZDR	5	3500	600	47.2	141	1670	833	3.48	56.8	171

注1) 安装基准系列(马达适用表记载系列)以外的马达时,每次都是与我们联系。(法兰尺寸可能不同)

注2) 输入轴换算惯性力矩仅为减速机的数值,不包括马达的惯性力矩。

注3) 最高输入转速为5000rpm。正常情况下请转速控制在3000rpm以下。

注4) 容许径向负荷表示输出轴中央部位的值。

注5) 全部为斜齿轮适用范围。

注6) 马达的安装顺序请参照P31。

注7) 输出轴旋转方向与马达输入旋转方向相同。

Note1) In case of attachment to a motor beyond the standard models (motor matching series), contact us. (How to measure dimensions of the flange may be changed in some cases.)

Note2) The moment of inertia of input shaft conversion is only gained from the reducer, so it does not include moment of inertia of the motor.

Note3) The max. input speed is 5000rpm, and usually set to 3000rpm or less.

Note4) The permissible radial load is indicated on the center of the output shaft.

Note5) All values are within the range corresponding to helical gear.

Note6) For motor assembly procedure, see page 31.

Note7) Rotation of the output shaft is in the same direction as motor.

尺寸表 Dimensions

● 125ZDR3-5-3500

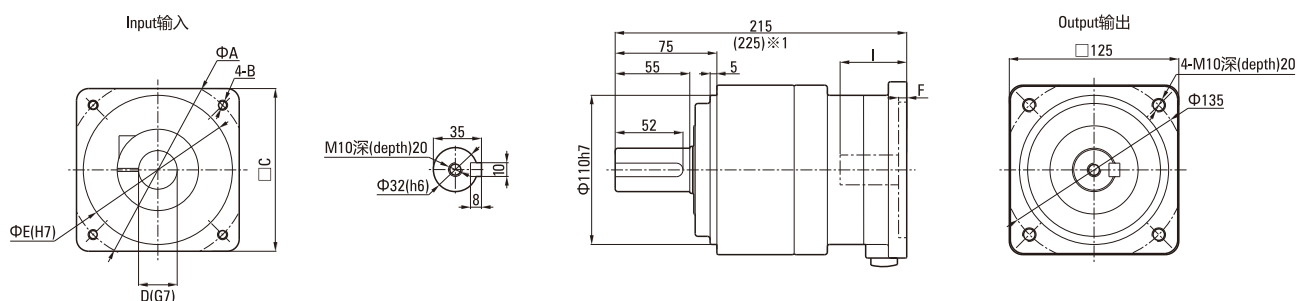

● 法兰部位详细尺寸表 Detailed Flange Dimensions Table

(单位Unit:mm)

马达种类 Motor Type	A	B	C	D	E	F	I
T1	130	M8深(depth)15	120	22	110	7	55
T2	-	-	-	-	-	-	-
T3	145	M8深(depth)15	130	28	110	7	65

● 概略重量12.0kg

Rough weight 12.0kg

● T1~3的详细情况请参照P.43

For details of T1~3, see page 43

4000W尺寸图与性能表

4000W DIMENSIONAL DRAWING & PERFORMANCE TABLE

■ 性能表 Performance Table (输入转速为3,000rpm时 When Input Speed Is 3000rpm)

额定输入 马达功率 Rated Input Motor	减速比 Reduction Ratio	系列号 Model				输出轴 转速 Outout Shaft Speed (rpm)	额定输出 扭矩 Standard Output Torque (N.m)	瞬间最大 输出扭矩 Instantaneous Max.Output Torque (N.m)	容许径向 负荷 Permissible Radial Load (N)	容许轴向 负荷 Permissible Axial Load (N)	输入轴换算 内部惯性力矩 Internal Moment Of inertia Of Input Shaftconversion ($\times 10^{-4}$ kg.m ²)	容许输出 扭矩 Permissible Output Torque (N.m)	瞬间最大容 许输出扭矩 Instantaneous Max. Permissible Output Torque (N.m)
		机座号 Type No.	系列号 Model	减速比 Reduction Ratio	马达功率 Motor								
4000W	1/3	125	ZDR	3	4000	1000	33.1	99.0	1370	686	5.78	44.1	132
	1/5	125	ZDR	5	4000	600	55.3	166	1670	833	3.75	56.8	171

注1) 安装基准系列(马达适用表记载系列)以外的马达时, 每次都是与我们联系。(法兰尺寸可能不同)

注2) 输入轴换算惯性力矩仅为减速机的数值, 不包括马达的惯性力矩。

注3) 最高输入转速为5000rpm。正常情况下请转速控制在3000rpm以下。

注4) 容许径向负荷表示输出轴中央部位的值。

注5) 全部为斜齿轮适用范围。

注6) 马达的安装顺序请参照P31。

注7) 输出轴旋转方向与马达输入旋转方向相同。

Note1) In case of attachment to a motor beyond the standard models (motor matching series), contact us. (How to measure dimensions of the flange may be changed in some cases.)

Note2) The moment of inertia of input shaft conversion is only gained from the reducer, so it does not include moment of inertia of the motor.

Note3) The max. input speed is 5000rpm, and usually set to 3000rpm or less.

Note4) The permissible radial load is indicated on the center of the output shaft.

Note5) All values are within the range corresponding to helical gear.

Note6) For motor assembly procedure, see page 31.

Note7) Rotation of the output shaft is in the same direction as motor.

■ 尺寸表 Dimensions

● 125ZDR3-5-4000

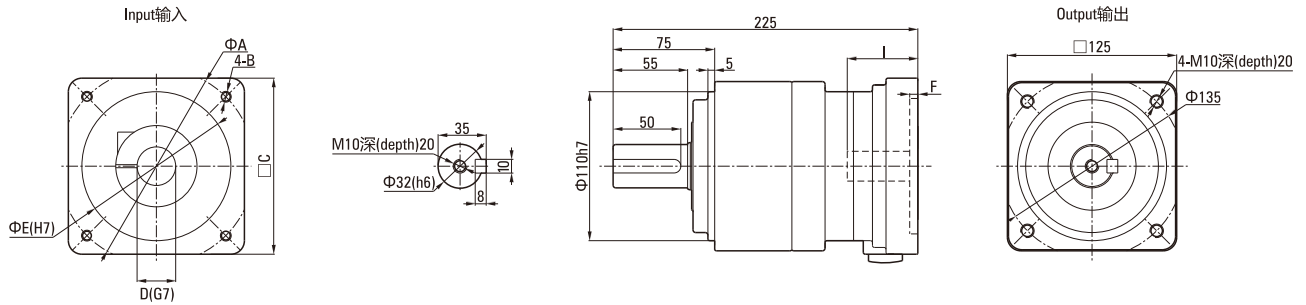

● 法兰部位详细尺寸表 Detailed Flange Dimensions Table

(单位Unit:mm)

马达种类 Motor Type	A	B	C	D	E	F	I
T1	145	M8深(depth)15	130	24	110	7	65
T2	145	M8深(depth)15	130	28	110	7	65
T3	-	-	-	-	-	-	-

● 概略重量13.0kg

Rough weight 13.0kg

● T1~3的详细情况请参照P43

For details of T1~3, see page 43

4500W尺寸图与性能表

4500W DIMENSIONAL DRAWING & PERFORMANCE TABLE

性能表 Performance Table (输入转速为3,000rpm时 When Input Speed Is 3000rpm)

额定输入 马达功率 Rated Input Motor	减速比 Reduction Ratio	系列号 Model				输出轴 转速 Outout Shaft Speed (rpm)	额定输出 扭矩 Standard Output Torque (N.m)	瞬间最大 输出扭矩 Instantaneous Max.Output Torque (N.m)	容许径向 负荷 Permissible Radial Load (N)	容许轴向 负荷 Permissible Axial Load (N)	输入轴换算 内部惯性力矩 Of Input Shaftconversion (x10 ⁻⁴ kg.m ²)	容许输出 扭矩 Permissible Output Torque (N.m)	瞬间最大容 许输出扭矩 Instantaneous Max. Permissible Output Torque (N.m)
		机座号 Type No.	系列号 Model	减速比 Reduction Ratio	马达功率 Motor								
4500W	1/3	125	ZDR	3	4500	1000	37.7	113	1370	686	5.78	44.1	132

注1) 安装基准系列(马达适用表记载系列)以外的马达时,每次都是与我们联系。(法兰尺寸可能不同)

注2) 输入轴换算惯性力矩仅为减速机的数值,不包括马达的惯性力矩。

注3) 最高输入转速为5000rpm。正常情况下请转速控制在3000rpm以下。

注4) 容许径向负荷表示输出轴中央部位的值。

注5) 全部为斜齿轮适用范围。

注6) 马达的安装顺序请参照P31。

注7) 输出轴旋转方向与马达输入旋转方向相同。

Note1) In case of attachment to a motor beyond the standard models (motor matching series),contact us. (How to measure dimensions of the flange may be changed in some cases.)

Note2) The moment of inertia of input shaft conversion is only gained from the reducer, so it does not include moment of inertia of the motor.

Note3) The max. input speed is 5000rpm, and usually set to 3000rpm or less.

Note4) The permissible radial load is indicated on the center of the output shaft.

Note5) All values are within the range corresponding to helical gear.

Note6) For motor assembly procedure, see page 31.

Note7) Rotation of the output shaft is in the same direction as motor.

尺寸表 Dimensions

● 125ZDR3-4500

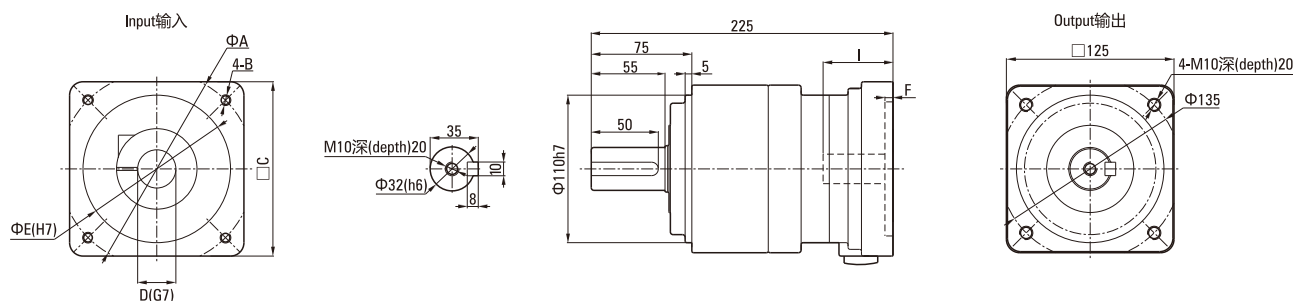

● 法兰部位详细尺寸表 Detailed Flange Dimensions Table

(单位Unit:mm)

马达种类 Motor Type	A	B	C	D	E	F	I
T1	145	M8深(depth)15	130	24	110	7	65
T2	-	-	-	-	-	-	-
T3	-	-	-	-	-	-	-

• 概略重量13.0kg

Rough weight 13.0kg

• T1~3的详细情况请参照P.43

For details of T1~3, see page 43

5000W尺寸图与性能表

5000W DIMENSIONAL DRAWING & PERFORMANCE TABLE

■ 性能表 Performance Table (输入转速为3,000rpm时 When Input Speed Is 3000rpm)

额定输入 马达功率 Rated Input Motor	减速比 Reduction Ratio	系列号 Model				输出轴 转速 Outout Shaft Speed (rpm)	额定输出 扭矩 Standard Output Torque (N.m)	瞬间最大 输出扭矩 Instantaneous Max.Output Torque (N.m)	容许径向 负荷 Permissible Radial Load (N)	容许轴向 负荷 Permissible Axial Load (N)	输入轴换算 内部惯性力矩 Of Input Shaftconversion Internal Moment Of inertia ($\times 10^{-4}$ kg.m ²)	容许输出 扭矩 Permissible Output Torque (N.m)	瞬间最大容 许输出扭矩 Instantaneous Max. Permissible Output Torque (N.m)
		机座号 Type No.	系列号 Model	减速比 Reduction Ratio	马达功率 Motor								
5000W	1/3	125	ZDR	3	5000	1000	42.9	128	1370	686	5.78	44.1	132

注1) 安装基准系列(马达适用表记载系列)以外的马达时, 每次都是与我们联系。(法兰尺寸可能不同)

注2) 输入轴换算惯性力矩仅为减速机的数值, 不包括马达的惯性力矩。

注3) 最高输入转速为5000rpm。正常情况下请转速控制在3000rpm以下。

注4) 容许径向负荷表示输出轴中央部位的值。

注5) 全部为斜齿轮适用范围。

注6) 马达的安装顺序请参照P31。

注7) 输出轴旋转方向与马达输入旋转方向相同。

Note1) In case of attachment to a motor beyond the standard models (motor matching series), contact us. (How to measure dimensions of the flange may be changed in some cases.)

Note2) The moment of inertia of input shaft conversion is only gained from the reducer, so it does not include moment of inertia of the motor.

Note3) The max. input speed is 5000rpm, and usually set to 3000rpm or less.

Note4) The permissible radial load is indicated on the center of the output shaft.

Note5) All values are within the range corresponding to helical gear.

Note6) For motor assembly procedure, see page 31.

Note7) Rotation of the output shaft is in the same direction as motor.

■ 尺寸表 Dimensions

● 125ZDR3-5000

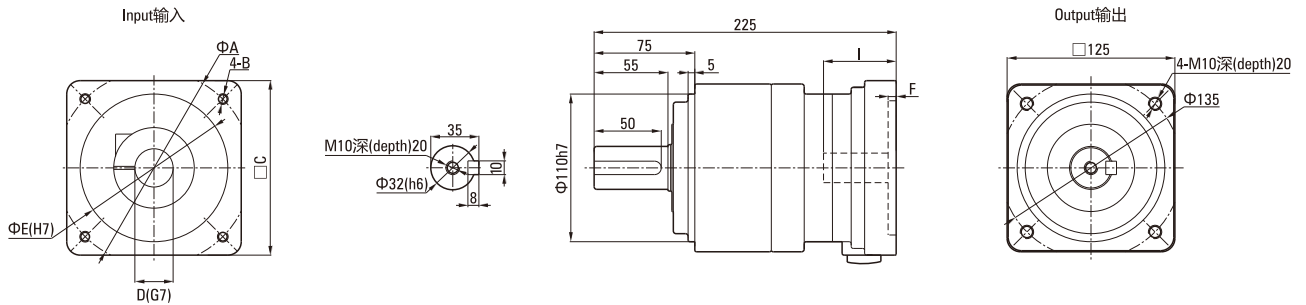

● 法兰部位详细尺寸表 Detailed Flange Dimensions Table

(单位Unit:mm)

马达种类 Motor Type	A	B	C	D	E	F	I
T1	145	M8深(depth)15	130	24	110	7	65
T2	145	M8深(depth)15	130	28	110	7	65
T3	145	M8深(depth)15	130	28	110	7	65

• 概略重量13.0kg

Rough weight 13.0kg

• T1~3的详细情况请参照P43

For details of T1~3, see page 43

安装 ASSEMBLY

■ 安装马达的步骤 Assembly Procedure

客户自行安装伺服马达时，请按以下要领进行安装。伺服马达的尺寸多种多样，除指定的产品外，有些马达可能会无法连接法兰，因为，一定要使用您订货时指定的马达。

If a customer personally assembles the servo motor and reducer please use the following tip. The reducer flange to which the servo motor is attached has different dimensions based on the motor specified. Therefore, assembly may be impossible for some motor. Make sure the correct motor is specified before ordering the reducer.

1. 安装无键马达 Spec. In Case Of Assembling A Motor Without Key

①取下橡胶帽，转动输入轴，使螺栓头和紧定螺钉的孔吻合。并确认固定螺栓已松开。

Take off the rubber cap, turn the input shaft, and match the head of the bolt to the hole of the rubber cap. Make sure that the set bolt is loosened.

②将马达轴平稳地插入输入轴（请确保不受阻塞地顺畅的插入）。请充分注意不要让马达倾斜插入。

Gradually put the motor shaft into the input shaft (Ensure that it is smoothly put in without jam). Be careful not to be inserted with the motor tilted.

③将马达固定在减速机上，并按指定的扭矩将螺栓拧紧。参考表1

Attach the motor to the reducer and fasten the bolt with designated fastening torque. See table 1.

④使用扭矩扳手等工具，按指定的扭矩将输入轴的固定螺栓拧紧。参考表2

Fasten the set bolt of the input shaft with designated fastening torque wrench, etc. See table 2.

⑤盖上橡胶帽。安装到此结束。

Put on the rubber cap. It is the end of assembling.

● 表1 Table1

马达固定螺栓 Motor Combination Bolt	拧紧扭矩 Fastening Torque	
	(N·m)	(kgf·cm)
M3	1.0	10
M4	3.0	30
M5	5.8	60
M6	9.8	100
M8	19.6	200
M10	39.2	400
M12	68.6	700
M16	168	1650

● 表2 Table2

固定螺栓 Combination Bolt	拧紧扭矩 Fastening Torque	
	(N·m)	(kgf·cm)
M3	1.5	15
M4	3.5	35
M5	7.1	71
M6	12	120
M8	30	300
M10	60	612

带键槽式马达的键取下后，可以像上述无键马达一样安装。无需担心会滑动。

You can assemble the motor with keyway like above when take off the key. There is no risk of dislocation.

● ZDR 系列示意图
ZDR Series Schematic Diagram

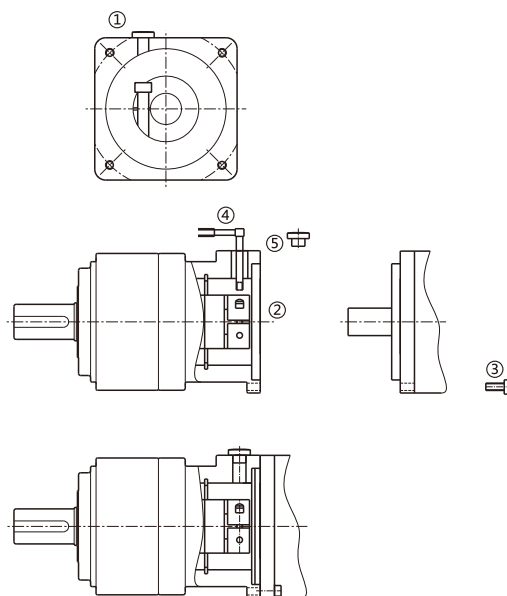

安装 ASSEMBLY

2. 安装带键槽马达 Spec. In Case Of Assembling A Motor With Key

- ① 取下橡胶帽，转动输入轴，使螺栓头和橡胶帽的孔吻合。
Take off the rubber cap, turn the input shaft, and match the head of the bolt to the hole of the rubber cap.
- ② 在马达轴上涂上防锈剂（二氧化钼等），并将键与键槽对上后平稳地插入输出轴（请确保不受阻塞地顺畅的插入）。请务必注意不要让马达倾斜插入。
Coat carbon formation inhibitors (molybdenum dioxide etc.) onto the motor shaft, match the key slot, and gradually.
- ③ 将马达安装在减速机上，并按指定的扭矩将螺栓拧紧。参考表1
Combine the motor with the reducer and fasten with the designated fastening bolt. See table 1
- ④ 使用扭矩扳手等工具按指定的扭矩将输入轴的固定螺栓拧紧，并确认键已被压紧。参考表3
For set bolt of the input shaft, fasten using torque wrench with the designated fastening torque with the key firmly pressed. See table 3
- ⑤ 盖上橡胶帽。安装到此结束。Put on a rubber cap. The is the end.

● 表3 Table3

固定螺栓 Combination Bolt	拧紧扭矩 Fastening Torque	
	(N·m)	(kgf·cm)
M4	2.0	20
M5	4.3	43
M6	7.3	73
M8	16.8	168

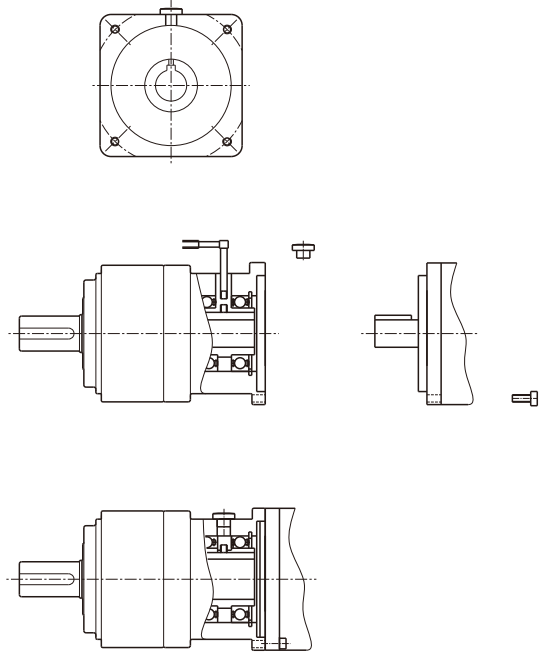

■ 减速机的安装 Reducer Assembly

将减速机安装在设备上时，请在确认安装面平坦且无毛刺等后，使用扭矩扳手等工具按指定的扭矩用螺栓将其固定。参考表4
Jointing with reducer in case of jointing a reducer with the device, make sure that the combining side is plane without inconsistency, and when assemble reducer outo equipment, ensuring assembly surface smooth and without burr. See Table 4.

● 表4 Table4

减速机固定螺栓 Reducer Combination Bolt	拧紧扭矩 Fastening Torque	
	(N·m)	(kgf·cm)
M5	5.8	60
M6	9.8	100
M8	19.6	200
M10	39.2	400
M12	68.6	700
M16	16.8	1650

■ 连接输出轴 Connection To The Output Shaft

注意事项 Cautions:

- 1、在输出轴上安装耦合器、滑轮等时，请勿在输出轴上施加过大的轴向负荷。
When assemble a coupling, pulley, etc. onto the output shaft, make sure that excessive axial load not be given to the output shaft.
- 2、请勿使用强力将轴敲入，以免使轴承或减速机内部受到损伤。
In case of strongly hitting the shaft with a hammer, the shaft inlet or the inside of the reducer may be damaged, therefore it shall be prohibited.
- 3、安装的耦合器等的轴和键槽如有较大松动，可能会导致设备烧毁，安装时请充分注意。
If the shaft or key of a coupling assembled is loosed, it may cause carbonization, so be careful when assembling.
- 4、安装耦合器等时，请使用固定螺栓来将键固定住。
For assembling of a coupling, fix the key with a set bolt.
- 5、连接时请充分调校轴心。
Please adjust shaft centre carefully in connecting.

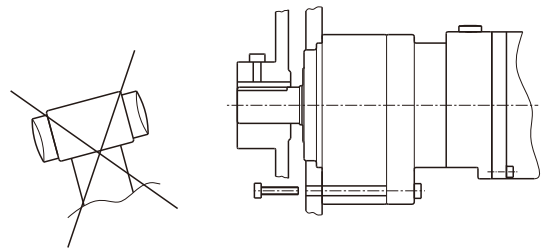

ZDG系列减速机 ZDG SERIES GEAR BOX

剖视图 Sectional Drawing

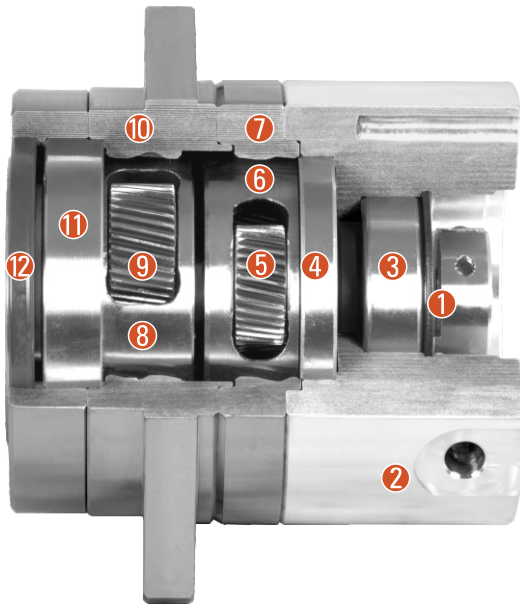

- ① 精密器夹系统 Precision machine clip system
- ② 适配电机法兰 Adapter motor flange
- ③ 太阳轮轴承 Sun wheel bearing
- ④ 行星架轴承 Planetary frame bearing
- ⑤ 输入行星轮 Input planetary wheel
- ⑥ 行星架 Planetary frame
- ⑦ 输入内齿轮 Input internal gear
- ⑧ 输出行星架 Output planetary frame
- ⑨ 输出行星轮 Output planetary wheel
- ⑩ 输出内齿轮 Output internal gear
- ⑪ 交叉滚子轴承 Cross roller bearing
- ⑫ 输出油封 Output oil seal

减速比 · 机座号 Type And Model Number

功率 Power (W)	减速比 (单级) Reduction Ratio (Single Stage)						减速比 (两级) Reduction Ratio (Two Stage)												
	※1 1:3.67	1:4	1:5	1:7	1:9	1:10	※2 1:11	1:15 1:15.4	1:20	1:21	1:25	1:33	1:35	1:40	1:45	1:50	1:70	1:81	1:100
50	60						60												
100	60						60												
200	60						60												
400	60						60												
750	90						120												
1000	90						120												
1500	90						120												
2000	90	120					120												
2500	120						170												
3000	120						170												
3500	120						170												
4000	120						170												
4500	120						170												
5000	120						170												

※1 1:3.67是1:3/11=1:3.666...

※2 60是1:15、90,120,170是1:15.4

性能表 PERFORMANCE TABLE

60~120: 输入转速为3,000rpm时 When Input Speed Is 3,000rpm 170: 输入转速为2,000rpm时 When Input Speed Is 2,000rpm

马达额定 转数 Motor rating Revolutions	机座号 Type No.	减速比 Reduction Ratio	容许输出 扭矩	容许最大 输出扭矩	紧急时最大 输出扭矩	容许平均输入 输出转速	容许最高 输入转速	大概重量 (kg) Approximate Weight		容许径向负荷 (N) Permissible Radial Load		容许轴向 负荷	容许力矩 Allow Moment
			※1	※2	※3	※4	※5	法兰 Flange	输出轴 Output Shaft	法兰 Flange	输出轴 Output Shaft	※8	※9
			(N·m)	(N·m)	(N·m)	(min ⁻¹)	(min ⁻¹)			※6	※7	(N)	(Nm)
3000	60	3.67	6.82	24.8	49.6	3000	6000	1.1	1.2	553	202	826	38
		4	7.16	27.0	54.1					568	207	846	
		5	7.87	27.0	54.1					607	221	906	
		7	9.29	25.7	51.3					672	245	927	
		9	10.5	23.7	47.3					724	264	927	
		10	10.8	21.6	43.3					747	272	927	
		11	9.43	26.4	52.7					769	280	927	
		15	10.9	27.2	57.5					844	308	927	
		20	11.5	26.8	53.7					920	335	927	
		21	12.0	28.8	57.5					934	340	927	
		25	12.7	28.8	57.5			984	359	927			
		33	13.1	26.4	52.7			1070	390	927			
		35	13.0	25.9	51.8			1090	397	927			
		40	13.4	26.8	53.7			1130	413	927			
		45	14.4	28.8	57.5			1170	428	927			
		50	14.4	28.8	57.5			1210	442	927			
		70	13.0	25.9	51.8			1340	488	927			
		81	11.8	23.6	47.2			1400	510	927			
		100	10.8	21.6	43.1			1490	544	927			
		3000	90	3.67	21.7			92.6	185	3000	6000	2.3	
4	22.5			101	202	1090	460	1630					
5	24.6			106	212	1170	491	1750					
7	28.6			101	203	1290	544	1930					
9	32.4			81.9	164	1400	586	2080					
10	34.1			73.1	146	1440	605	2150					
11	23.2			81.8	164	1480	622	2210					
15.4	33.2			110	220	1640	689	2450					
20	36.2			116	232	1770	745	2650					
21	37.7			123	246	1800	756	2650					
25	39.7			123	246	1900	796	2650					
33	41.7			110	220	2060	865	2650					
35	46.1			103	207	2100	881	2650					
40	44.6			116	232	2180	917	2650					
45	47.3			123	246	2260	950	2650					
50	48.8			123	246	2330	980	2650					
70	50.3			101	201	2580	1080	2650					
81	40.8			81.7	163	2700	1130	2650					
100	36.4			72.9	146	2870	1210	2650					
3000	120			3.67	71.9	255	511	3000	6000			6.7	8.1
		4	74.7	262	524	1910	718			2850			
		5	82.6	295	589	2040	768			3050			
		7	96.5	240	480	2260	850			3370			
		9	96.0	192	384	2440	916			3640			
		10	80.8	162	323	2510	946			3740			
		11	60.5	206	411	2590	973			3740			
		15.4	110	285	570	2860	1080			3740			
		20	120	292	585	3100	1160			3740			
		21	126	318	635	3140	1180			3740			
		25	133	318	635	3310	1240			3740			
		33	138	285	570	3600	1350			3740			
		35	132	265	529	3660	1380			3740			
		40	146	292	585	3810	1430			3740			
		45	159	318	635	3950	1480			3740			
		50	159	318	635	4070	1530			3740			
		70	132	265	529	4510	1700			3740			
		81	95.7	191	383	4710	1770			3740			
		100	80.6	161	322	5020	1890			3740			
		2000	170	3.67	174	669	1340			3000	3000	16	19
4	187			644	1290	4280	1790	6400					
5	202			639	1280	4580	1920	6840					
7	245			578	1160	5070	2120	7560					
9	200			400	801	5470	2290	8160					
10	199			398	796	5640	2360	8420					
11	170			501	1000	5800	2430	8660					
15.4	266			702	1400	6420	2690	9580					
20	301			715	1410	6940	2910	10400					
21	309			710	1420	7050	2950	10500					
25	326			710	1420	7430	3110	10800					
33	335			765	1530	8070	3380	10800					
35	316			632	1260	8210	3440	10800					
40	358			715	1430	8550	3580	10800					
45	355			710	1420	8860	3710	10800					
50	355			710	1420	9140	3830	10800					
70	316			632	1260	10100	4230	10800					
81	200			399	798	10600	4420	10800					
100	198			397	793	11300	4710	10800					

※1 容许输出扭矩是寿命20000小时的值。
 ※2 容许最大输出轴扭矩是启动/停止时的容许值。
 ※3 紧急时最大输出扭矩是冲击等作用时的容许值。
 ※4 容许平均输入转速中的平均输入转速的最大值。
 ※5 容许最高输入转速是在非连续运转条件下的最高输入转速。
 ※6 容许径向负荷(法兰)是作用于交叉滚子轴承时的值(轴向负荷0)。
 ※7 容许径向负荷(输出轴)是作用于交叉滚子轴承时的值(轴向负荷0)。
 ※8 容许推力负荷是作用于输出轴心时的值(径向负荷0)。
 ※9 容许力矩是能容许的最大值。

※1 allows the output torque is the value of life 20000 hours.
 ※2 maximum output torque is allowed to start and stop when the value of.
 ※3 emergency when the maximum output torque is to allow the value of the impact effect.
 ※4 the maximum allowable average input speed of the average input speed.
 ※5 the maximum allowable input speed is the highest input speed continuous operation under the condition of non.
 ※6 permissible radial load (flange) is acting on the cross roller bearing value (0 axial load).
 ※7 permissible radial load (output shaft) is acting on the cross roller bearing value (0 axial load).
 ※8 allow the thrust load is applied to the output value of the axial (radial load 0).
 ※9 is the maximum allowable moment can allow the.

输出扭矩 · 惯性力矩 (60 · 90)

OUTPUT TORQUE AND MOMENT OF INERTIA (60·90)

■ 输入转速为3,000rpm时(60) When Input Speed Is 3,000rpm (60)

※1 型号 Type				输出轴 转速 Output Shaft Speed	※2额定 输出轴扭矩 ※2 Rated Output Shaft Torque	※3瞬间最大 输出轴扭矩 ※3 Instantaneous Max.Output Torque	惯性力矩 X10 ⁻⁴ kgm ² Inertia Moment	
机座号 Type No.	系列号 Model	减速比 Reduction Ratio	马达功率 Motor Power	(rpm)	(Nm)	(Nm)	法兰 Flange	输出轴 Output Shaft
60	ZDG□	5	50	600	0.255	0.764	0.0494	0.0551
60	ZDG□	5	100	600	0.986	2.96	0.0494	0.055
60	ZDG□	5	200	600	2.55	7.64	0.127	0.1331
60	ZDG□	5	400	600	5.60	16.8	0.127	0.133
60	ZDG□	9	50	333	0.659	1.98	0.0349	0.0366
60	ZDG□	9	100	333	2.12	6.36	0.0349	0.0366
60	ZDG□	9	200	333	4.81	14.4	0.113	0.114
60	ZDG□	9	400	333	10.3	23.7	0.113	0.114
60	ZDG□	11	50	273	0.525	1.57	0.0752	0.0764
60	ZDG□	11	100	273	2.10	6.30	0.0752	0.0764
60	ZDG□	11	200	273	5.46	16.4	0.154	0.155
60	ZDG□	15	50	273	1.38	4.15	0.0731	0.0738
60	ZDG□	15	100	273	3.63	10.9	0.0731	0.0738
60	ZDG□	15	200	273	8.02	24.1	0.152	0.152
60	ZDG□	21	50	143	2.67	8.02	0.0482	0.0485
60	ZDG□	21	100	143	5.88	17.6	0.0482	0.0485
60	ZDG□	21	200	143	12.0	28.8	0.126	0.126
60	ZDG□	23	50	91	4.20	12.6	0.0330	0.0331
60	ZDG□	33	100	91	9.24	26.4	0.0330	0.0331
60	ZDG□	45	50	67	5.44	16.3	0.0327	0.0328
60	ZDG□	45	100	67	11.7	28.8	0.0327	0.0328
60	ZDG□	81	30	37	5.10	15.3	0.0326	0.0326
60	ZDG□	81	50	37	9.79	23.6	0.0326	0.0326

■ 输入转速为3,000rpm时(90) When Input Speed Is 3,000rpm(90)

※1 型号 Type				输出轴 转速 Output Shaft Speed	※2额定 输出轴扭矩 ※2 Rated Output Shaft Torque	※3瞬间最大 输出轴扭矩 ※3 Instantaneous Max.Output Torque	惯性力矩 X10 ⁻⁴ kgm ² Inertia Moment	
机座号 Type No.	系列号 Model	减速比 Reduction Ratio	马达功率 Motor Power	(rpm)	(Nm)	(Nm)	法兰 Flange	输出轴 Output Shaft
90	ZDG□	5	400	600	4.71	14.1	0.359	0.396
90	ZDG□	5	750	600	10.3	30.8	0.663	0.701
90	ZDG□	5	1000	600	14.0	42.0	1.80	1.84
90	ZDG□	5	1500	600	22.0	65.9	1.80	1.84
90	ZDG□	9	200	333	4.24	12.7	0.250	0.261
90	ZDG□	9	400	333	9.62	28.9	0.250	0.261
90	ZDG□	9	750	333	19.3	58.0	0.554	0.566
90	ZDG□	9	1000	333	26.3	79.0	1.69	1.70
90	ZDG□	11	200	273	5.04	15.1	0.429	0.437
90	ZDG□	11	400	273	11.5	34.4	0.429	0.437
90	ZDG□	11	750	273	23.1	69.3	0.701	0.708
90	ZDG□	15.4	200	195	8.04	24.1	0.342	0.346
90	ZDG□	15.4	400	195	17.2	51.7	0.342	0.346
90	ZDG□	15.4	750	195	33.2	101	0.613	0.617
90	ZDG□	21	200	143	11.0	32.9	0.333	0.335
90	ZDG□	21	400	143	23.5	70.6	0.333	0.335
90	ZDG□	33	100	91	7.77	23.3	0.0619	0.0627
90	ZDG□	33	200	91	17.6	52.9	0.235	0.236
90	ZDG□	33	400	91	37.0	110	0.235	0.236
90	ZDG□	45	100	67	10.6	31.8	0.0601	0.0605
90	ZDG□	45	200	67	24.1	72.2	0.233	0.234
90	ZDG□	45	400	67	47.3	123	0.233	0.234
90	ZDG□	81	50	37	7.47	22.4	0.0336	0.0336
90	ZDG□	81	100	37	19.6	58.8	0.0336	0.0336
90	ZDG□	81	200	37	40.8	81.7	0.112	0.112

※ 有扭矩限制的机种。详细情况请咨询营业部。

※ 额定输出扭矩是马达额定扭矩时减速机的输出扭矩。

※ 瞬间最大输出扭矩是马达瞬间最大扭矩时减速机的输出扭矩。

但是，马达的瞬间最大扭矩是假设为额定扭矩的3倍时的值。

※ 马达的瞬间最大扭矩不是额定扭矩3倍的情况下，请事前与本公司联系。

※ 上述减速比以外的情况请咨询营业部。

※ The torque limit model. In detail, please contact the sales department.

※ The rated output torque motor rated torque reducer output torque.

※ The instantaneous maximum output torque motor instantaneous maximum torque.

※ when the output torque of reducer. However, the instantaneous maximum torque of the motor is assumed to be 3 times that of the rated torque.

※ The situation of motor instantaneous maximum torque Rated torque is 3 times, please contact in advance with the company.

※ If the reduction ratio of the situation outside the sales office to please.

输出扭矩 · 惯性力矩 (120)

OUTPUT TORQUE AND MOMENT OF INERTIA (120)

■ 输入转速为3,000rpm时(120) When Input Speed Is 3,000rpm (120)

※1 型号 Type				输出轴 转速 Output Shaft Speed	※2额定 输出轴扭矩 ※2 Rated Output Shaft Torque	※3瞬间最大 输出轴扭矩 ※3 Instantaneous Max.Output Torque	惯性力矩 X10 ⁻⁴ kgm ² Inertia Moment	
机座号 Type No.	系列号 Model	减速比 Reduction Ratio	马达功率 Motor Power	(rpm)	(Nm)	(Nm)	法兰 Flange	输出轴 Output Shaft
120	ZDG□	5	1000	600	12.1	36.3	2.51	2.72
120	ZDG□	5	1500	600	20.0	60.1	2.51	2.72
120	ZDG□	5	2000	600	28.0	84.0	2.51	2.72
120	ZDG□	5	2500	600	35.8	107	2.51	2.72
120	ZDG□	5	3000	600	43.0	129	4.12	4.33
120	ZDG□	5	3500	600	51.2	154	4.12	4.33
120	ZDG□	5	4000	600	58.5	176	4.12	4.33
120	ZDG□	5	4500	600	65.9	198	4.12	4.33
120	ZDG□	5	5000	600	73.2	220	4.12	4.33
120	ZDG□	9	750	333	17.6	52.8	1.04	1.11
120	ZDG□	9	1000	333	24.6	73.9	2.05	2.12
120	ZDG□	9	1500	333	37.8	113	2.05	2.12
120	ZDG□	9	2000	333	51.5	155	2.05	2.12
120	ZDG□	9	2500	333	65.9	192	2.05	2.12
120	ZDG□	9	3000	333	79.0	192	3.66	3.73
120	ZDG□	9	3500	333	92.2	192	3.66	3.73
120	ZDG□	11	750	273	19.9	59.8	1.77	1.82
120	ZDG□	11	1000	273	28.7	86.1	2.81	2.86
120	ZDG□	11	1500	273	45.1	135	2.81	2.86
120	ZDG□	11	2000	273	60.5	185	2.81	2.86
120	ZDG□	15.4	750	195	30.9	92.6	1.47	1.49
120	ZDG□	15.4	1000	195	43.1	129	2.51	2.53
120	ZDG□	15.4	1500	195	66.1	198	2.51	2.53
120	ZDG□	15.4	2000	195	88.2	265	2.51	2.53
120	ZDG□	15.4	2500	195	110	285	2.51	2.53
120	ZDG□	21	750	143	42.1	126	1.43	1.45
120	ZDG□	21	1000	143	58.8	176	2.47	2.48
120	ZDG□	21	1500	143	90.2	271	2.47	2.48
120	ZDG□	21	2000	143	120	318	2.47	2.48
120	ZDG□	33	400	91	34.4	103	0.345	0.350
120	ZDG□	33	750	91	69.3	208	0.941	0.946
120	ZDG□	33	1000	91	94.5	283	1.86	1.86
120	ZDG□	33	1500	91	138	285	1.86	1.86
120	ZDG□	45	400	67	47.0	141	0.338	0.341
120	ZDG□	45	750	67	94.5	283	0.934	0.936
120	ZDG□	45	1000	67	129	318	1.85	1.85
120	ZDG□	81	200	37	42.3	127	0.235	0.236
120	ZDG□	81	400	37	88.7	191	0.235	0.236

※ 有扭矩限制的机种。详细情况请咨询营业部。

※ 额定输出扭矩是马达额定扭矩时减速机的输出扭矩。

※ 瞬间最大输出扭矩是马达瞬间最大扭矩时减速机的输出扭矩。

但是，马达的瞬间最大扭矩是假设为额定扭矩的3倍时的值。

※ 马达的瞬间最大扭矩不是额定扭矩3倍的情况下，请事前与本公司联系。

※ 上述减速比以外的情况请向营业部咨询。

※ The torque limit model. In detail, please contact the sales department.

※ The rated output torque motor rated torque reducer output torque.

※ The instantaneous maximum output torque motor instantaneous maximum torque.

※ when the output torque of reducer. However, the instantaneous maximum torque of the motor is assumed to be 3 times that of the rated torque.

※ The situation of motor instantaneous maximum torque Rated torque is 3 times, please contact in advance with the company.

※ If the reduction ratio of the situation outside the sales office to please.

输出扭矩 · 惯性力矩 (170) OUTPUT TORQUE AND MOMENT OF INERTIA (170)

■ 输入转速为2,000rpm时(170) When Input Speed Is 2,000rpm (170)

※1 型号 Type				输出轴 转速 Output Shaft Speed	※2额定 输出轴扭矩 ※2 Rated Output Shaft Torque	※3瞬间最大 输出轴扭矩 ※3 Instantaneous Max.Output Torque	惯性力矩 X10 ⁻⁴ kgm ² Inertia Moment	
机座号 Type No.	系列号 Model	减速比 Reduction Ratio	马达功率 Motor Power	(rpm)	(Nm)	(Nm)	法兰 Flange	输出轴 Output Shaft
170	ZDG□	5	3000	400	39.1	117	7.67	8.87
170	ZDG□	5	3500	400	46.8	140	7.67	8.87
170	ZDG□	5	4000	400	54.7	164	7.67	8.87
170	ZDG□	5	4500	400	61.6	185	7.67	8.87
170	ZDG□	5	5000	400	70.0	210	7.67	8.87
170	ZDG□	9	1000	222	20.6	61.9	3.75	4.12
170	ZDG□	9	1500	222	34.4	103	3.75	4.12
170	ZDG□	9	2000	222	48.1	144	3.75	4.12
170	ZDG□	9	2500	222	61.6	185	3.75	4.12
170	ZDG□	9	3000	222	75.6	227	4.96	5.33
170	ZDG□	9	3500	222	90.2	271	4.96	5.33
170	ZDG□	9	4000	222	103	309	4.96	5.33
170	ZDG□	9	4500	222	116	348	4.96	5.33
170	ZDG□	9	5000	222	132	395	4.96	5.33
170	ZDG□	11	1000	182	20.3	60.9	6.94	7.18
170	ZDG□	11	1500	182	36.7	110	6.94	7.18
170	ZDG□	11	2000	182	53.2	160	6.94	7.18
170	ZDG□	11	2500	182	70.0	210	6.94	7.18
170	ZDG□	11	3000	182	86.1	258	8.12	8.37
170	ZDG□	11	3500	182	103	309	8.12	8.37
170	ZDG□	11	4000	182	120	361	8.12	8.37
170	ZDG□	11	4500	182	135	406	8.12	8.37
170	ZDG□	11	5000	182	151	462	8.12	8.37
170	ZDG□	15.4	1000	130	34.3	103	5.25	5.37
170	ZDG□	15.4	1500	130	57.3	172	5.25	5.37
170	ZDG□	15.4	2000	130	80.4	241	5.25	5.37
170	ZDG□	15.4	2500	130	103	309	5.25	5.37
170	ZDG□	15.4	3000	130	126	379	6.43	6.55
170	ZDG□	15.4	3500	130	151	453	6.43	6.55
170	ZDG□	15.4	4000	130	172	517	6.43	6.55
170	ZDG□	15.4	4500	130	198	595	6.43	6.55
170	ZDG□	15.4	5000	130	220	661	6.43	6.55
170	ZDG□	21	1000	95.2	46.8	140	5.04	5.11
170	ZDG□	21	1500	95.2	78.2	235	5.04	5.11
170	ZDG□	21	2000	95.2	110	329	5.04	5.11
170	ZDG□	21	2500	95.2	140	421	5.04	5.11
170	ZDG□	21	3000	95.2	172	517	6.23	6.29
170	ZDG□	21	3500	95.2	206	617	6.23	6.29
170	ZDG□	21	4000	95.2	235	706	6.23	6.29
170	ZDG□	21	4500	95.2	271	710	6.23	6.29
170	ZDG□	33	750	61	56.7	170	1.46	1.49
170	ZDG□	33	1000	61	81.9	246	3.11	3.14
170	ZDG□	33	1500	61	132	397	3.11	3.14
170	ZDG□	33	2000	61	181	542	3.11	3.14
170	ZDG□	33	2500	61	231	693	3.11	3.14
170	ZDG□	33	3000	61	283	765	4.11	4.14
170	ZDG□	45	750	44	77.3	232	1.42	1.43
170	ZDG□	45	1000	44	112	335	3.07	3.08
170	ZDG□	45	1500	44	180	541	3.07	3.08
170	ZDG□	45	2000	44	246	710	3.07	3.08
170	ZDG□	45	2500	44	315	710	3.07	3.08
170	ZDG□	81	400	25	78.3	235	0.348	0.353
170	ZDG□	81	750	25	162	399	0.964	0.969

※ 有扭矩限制的机种。详细情况请咨询营业部。

※ 额定输出扭矩是马达额定扭矩时减速机的输出扭矩。

※ 瞬间最大输出扭矩是马达瞬间最大扭矩时减速机的输出扭矩。

但是，马达的瞬间最大扭矩是假设为额定扭矩的3倍时的值。

※ 马达的瞬间最大扭矩不是额定扭矩3倍的情况下，请事前与本公司联系。

※ 上述减速比以外的情况请向营业部咨询。

※ The torque limit model. In detail, please contact the sales department.

※ The rated output torque motor rated torque reducer output torque.

※ The instantaneous maximum output torque motor instantaneous maximum torque.

※ when the output torque of reducer. However, the instantaneous maximum torque of the motor is assumed to be 3 times that of the rated torque.

※ The situation of motor instantaneous maximum torque Rated torque is 3 times, please contact in advance with the company.

※ If the reduction ratio of the situation outside the sales office to please.

尺寸图 DIMENSION CHART

减速机型号：60ZDGF(S) Reducer Type: 60ZDGF(S)

● 法兰输出型(ZDGF) Flange Type (ZDGF)

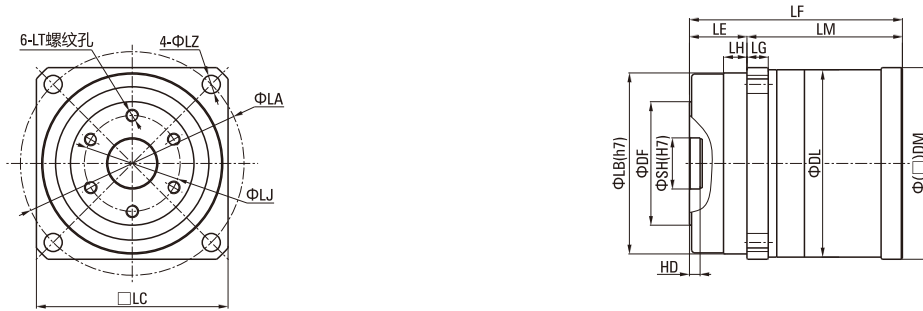

● 延长轴输出型(ZDGS) Extended Shaft Output (ZDGS)

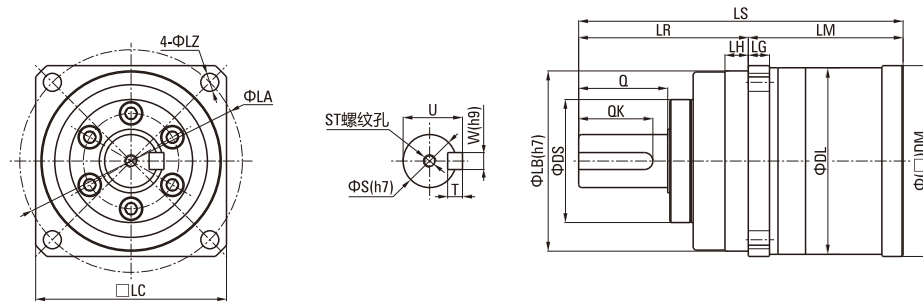

尺寸表 Dimensional Table

型号 Type				共同尺寸 Common Size										法兰型(ZDGF) Flange Type (ZDGF)						输出轴型(ZDGS) Output Shaft Type (ZDGS)									
机座号 Type No.	系列号 Model	减速比 Reduction Ratio	功率 Power	LA	LB	LC	LZ	LG	LH	LM	DL	DM	LE	LF	DF	SH	HD	LJ	LT	LR	LS	Q	DS	S	ST	W	T	U	QK
60	ZDG□	3.67-4-5-7-9-10	50	70	56	60	5.5	8	6.5	42.5	59	59	21	63.5	38	14	5	30	M4深7	58	100.5	28	39	16	M4深8	5	5	18	25
60	ZDG□	3.67-4-5-7-9-10	100	70	56	60	5.5	8	6.5	42.5	59	59	21	63.5	38	14	5	30	M4深7	58	100.5	28	39	16	M4深8	5	5	18	25
60	ZDG□	3.67-4-5-7-9-10	200	70	56	60	5.5	8	6.5	50.5	59	□60	21	71.5	38	14	5	30	M4深7	58	108.5	28	39	16	M4深8	5	5	18	25
60	ZDG□	3.67-4-5-7-9	400	70	56	60	5.5	8	6.5	50.5	59	□60	21	71.5	38	14	5	30	M4深7	58	108.5	28	39	16	M4深8	5	5	18	25
60	ZDG□	70-81-100	30	70	56	60	5.5	8	6.5	60	59	59	21	81	38	14	5	30	M4深7	58	118	28	39	16	M4深8	5	5	18	25
60	ZDG□	11-15-20-21-25-33 35-40-45-50-70-81	50	70	56	60	5.5	8	6.5	60	59	59	21	81	38	14	5	30	M4深7	58	118	28	39	16	M4深8	5	5	18	25
60	ZDG□	11-15-20-21-25-33 35-40-45-50	100	70	56	60	5.5	8	6.5	60	59	59	21	81	38	14	5	30	M4深7	58	118	28	39	16	M4深8	5	5	18	25
60	ZDG□	11-15-20-21	200	70	56	60	5.5	8	6.5	68	59	□60	21	89	38	14	5	30	M4深7	58	126	28	39	16	M4深8	5	5	18	25

尺寸图 DIMENSION CHART

减速机型号: 90ZDGF(S) Reducer Type: 90ZDGF(S)

● 法兰输出型(ZDGF) Flange Type (ZDGF)

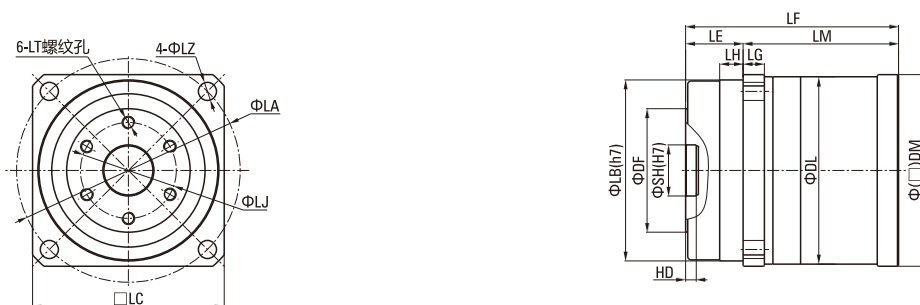

● 延长轴输出型(ZDGS) Extended Shaft Output (ZDGS)

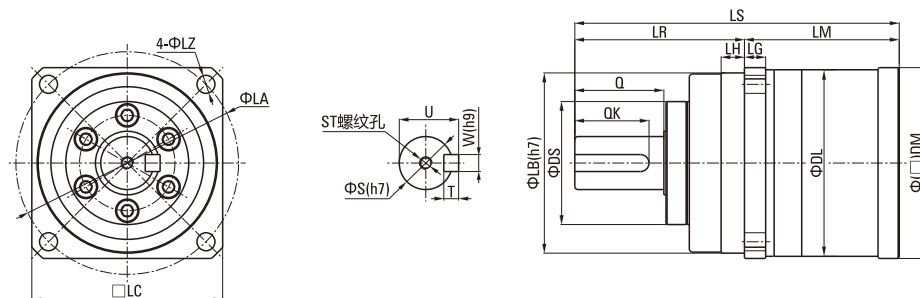

尺寸表 Dimensional Table

型号 Type				共同尺寸 Common Size									法兰型(ZDGF) Flange Type (ZDGF)						输出轴型(ZDGS) Output Shaft Type (ZDGS)										
机座号 Type No.	系列号 Model	减速比 Reduction Ratio	功率 Power	LA	LB	LC	LZ	LG	LH	LM	DL	DM	LE	LF	DF	SH	HD	LJ	LT	LR	LS	Q	DS	S	ST	W	T	U	QK
90	ZDG□	7-9-10	200	105	85	90	9	10	11	51	88	88	27	78	58	24	5	45	M6深10	80	131	42	39	25	M6深12	8	7	28	36
90	ZDG□	3.67-4-5-7-9-10	400	105	85	90	9	10	11	51	88	88	27	78	58	24	5	45	M6深10	80	131	42	58	25	M6深12	8	7	28	36
90	ZDG□	3.67-4-5-7-9-10	750	105	85	90	9	10	11	65	88	□90	27	92	58	24	5	45	M6深10	80	145	42	58	25	M6深12	8	7	28	36
90	ZDG□	3.67-4-5-7-9-10	1000	105	85	90	9	10	11	74	88	□100	27	101	58	24	5	45	M6深10	80	154	42	58	25	M6深12	8	7	28	36
90	ZDG□	3.67-4-5	1500	105	85	90	9	10	11	74	88	□100	27	101	58	24	5	45	M6深10	80	154	42	58	25	M6深12	8	7	28	36
90	ZDG□	3.67	2000	105	85	90	9	10	11	74	88	□100	27	101	58	24	5	45	M6深10	80	154	42	58	25	M6深12	8	7	28	36
90	ZDG□	33-40-45-50-70	100	105	85	90	9	10	11	66	88	68	27	93	58	24	5	45	M6深10	80	146	42	58	25	M6深12	8	7	28	36
90	ZDG□	11-15.4-20-21-25 33-35-40-45-50-70	200	105	85	90	9	10	11	73	88	88	27	100	58	24	5	45	M6深10	80	153	42	58	25	M6深12	8	7	28	36
90	ZDG□	11-15.4-20-21-25 33-35-40-45	400	105	85	90	9	10	11	73	88	88	27	100	58	24	5	45	M6深10	80	153	42	58	25	M6深12	8	7	28	36
90	ZDG□	11-15.4	750	105	85	90	9	10	11	81	88	□90	27	108	58	24	5	45	M6深10	80	161	42	58	25	M6深12	8	7	28	36
90	ZDG□	81-100	50	105	85	90	9	10	11	63	88	68	27	90	58	24	5	45	M6深10	80	143	42	58	25	M6深12	8	7	28	36
90	ZDG□	81-100	100	105	85	90	9	10	11	63	88	68	27	90	58	24	5	45	M6深10	80	143	42	58	25	M6深12	8	7	28	36
90	ZDG□	81	200	105	85	90	9	10	11	71	88	88	27	98	58	24	5	45	M6深10	80	151	42	58	25	M6深12	8	7	28	36

尺寸图 DIMENSION CHART

减速机型号: 120ZDGF(S) Reducer Type: 120ZDGF(S)

● 法兰输出型(ZDGF) Flange Type (ZDGF)

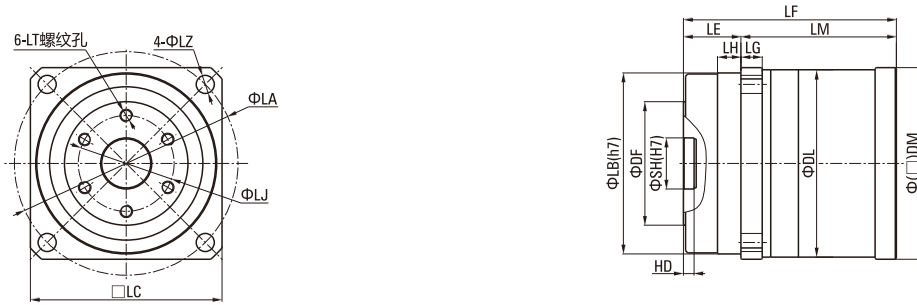

● 延长轴输出型(ZDGS) Extended Shaft Output (ZDGS)

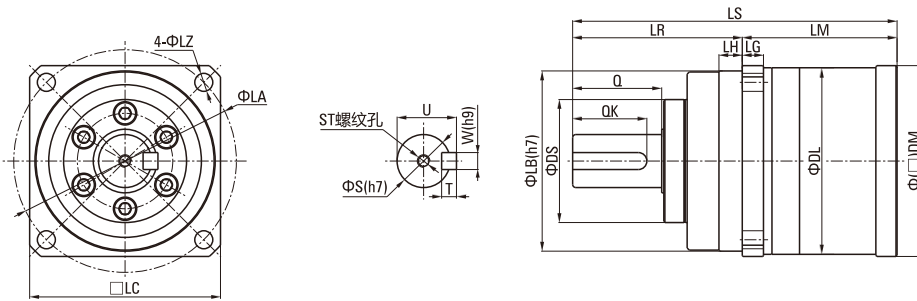

尺寸表 Dimensional Table

型号Type			共同尺寸 Common Size										法兰型(ZDGF) Flange Type (ZDGF)						输出轴型(ZDGS) Output Shaft Type (ZDGS)										
机座号 Type No.	系列号 Model	减速比 Reduction Ratio	功率 Power	LA	LB	LC	LZ	LG	LH	LM	DL	DM	LE	LF	DF	SH	HD	LJ	LT	LR	LS	Q	DS	S	ST	W	T	U	QK
120	ZDG□	7-9-10	750	135	115	120	11	13	15	67	118	118	35	102	79	32	5	60	M8深12	133	200	82	78	40	M10深20	12	8	43	70
120	ZDG□	3.67-4-5-7-9-10	1000	135	115	120	11	13	15	81	118	□120	35	116	79	32	5	60	M8深12	133	214	82	78	40	M10深26	12	8	43	70
120	ZDG□	3.67-4-5-7-9-10	1500	135	115	120	11	13	15	81	118	□120	35	116	79	32	5	60	M8深12	133	214	82	78	40	M10深27	12	8	43	70
120	ZDG□	3.67-4-5-7-9-10	2000	135	115	120	11	13	15	81	118	□120	35	116	79	32	5	60	M8深12	133	214	82	78	40	M10深28	12	8	43	70
120	ZDG□	3.67-4-5-7-9-10	2500	135	115	120	11	13	15	81	118	□120	35	116	79	32	5	60	M8深12	133	214	82	78	40	M10深29	12	8	43	70
120	ZDG□	3.67-4-5-7-9	3000	135	115	120	11	13	15	91	118	□130	35	126	79	32	5	60	M8深12	133	224	82	78	40	M10深30	12	8	43	70
120	ZDG□	3.67-4-5-7-9	3500	135	115	120	11	13	15	91	118	□130	35	126	79	32	5	60	M8深12	133	224	82	78	40	M10深31	12	8	43	70
120	ZDG□	3.67-4-5-7	4000	135	115	120	11	13	15	91	118	□130	35	126	79	32	5	60	M8深12	133	224	82	78	40	M10深32	12	8	43	70
120	ZDG□	3.67-4-5-7	4500	135	115	120	11	13	15	91	118	□130	35	126	79	32	5	60	M8深12	133	224	82	78	40	M10深33	12	8	43	70
120	ZDG□	3.67-4-5	5000	135	115	120	11	13	15	91	118	□130	35	126	79	32	5	60	M8深12	133	224	82	78	40	M10深34	12	8	43	70
120	ZDG□	33-35-40-45-50-70	400	135	115	120	11	13	15	87	118	94	35	122	79	32	5	60	M8深12	133	220	82	78	40	M10深21	12	8	43	70
120	ZDG□	11-15.4-20-21-25 33-35-40-45-50	750	135	115	120	11	13	15	94	118	118	35	129	79	32	5	60	M8深12	133	227	82	78	40	M10深22	12	8	43	70
120	ZDG□	100	100	135	115	120	11	13	15	74.5	118	68	35	109.5	79	32	5	60	M8深12	133	207.5	82	78	40	M10深23	12	8	43	70
120	ZDG□	81-100	200	135	115	120	11	13	15	81.5	118	94	35	116.5	79	32	5	60	M8深12	133	214.5	82	78	40	M10深24	12	8	43	70
120	ZDG□	81	400	135	115	120	11	13	15	81.5	118	94	35	116.5	79	32	5	60	M8深12	133	214.5	82	78	40	M10深25	12	8	43	70
120	ZDG□	11-15.4-20-21-25 33-35-40-45-50	1000	135	115	120	11	13	15	107	118	□120	35	142	79	32	5	60	M8深12	133	240	82	78	40	M10深35	12	8	43	70
120	ZDG□	11-15.4-20-21-25 33	1500	135	115	120	11	13	15	107	118	□120	35	142	79	32	5	60	M8深12	133	240	82	78	40	M10深36	12	8	43	70
120	ZDG□	11-15.4-20-21	2000	135	115	120	11	13	15	107	118	□120	35	142	79	32	5	60	M8深12	133	240	82	78	40	M10深37	12	8	43	70
120	ZDG□	15.4	2500	135	115	120	11	13	15	107	118	□120	35	142	79	32	5	60	M8深12	133	240	82	78	40	M10深38	12	8	43	70

尺寸图 DIMENSION CHART

■ 减速机型号: 170ZDGF(S) Reducer Type: 170ZDGF(S)

● 法兰输出型(ZDGF) Flange Type (ZDGF)



● 延长轴输出型(ZDGS) Extended Shaft Output (ZDGS)

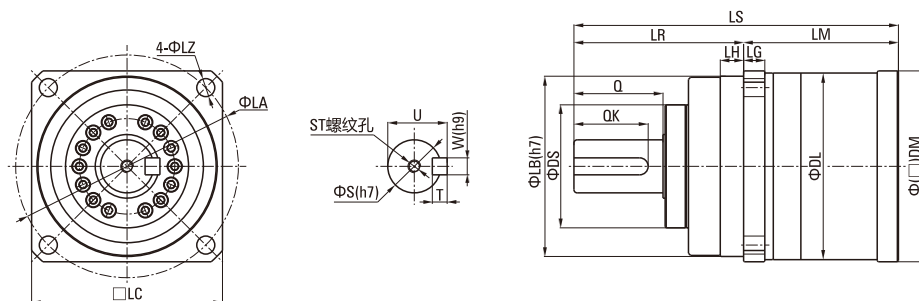

■ 尺寸表 Dimensional Table

型号 Type				共同尺寸 Common Size								法兰型(ZDGF) Flange Type (ZDGF)						输出轴型(ZDGS) Output Shaft Type (ZDGS)											
机座号 Type No.	系列号 Model	减速比 Reduction Ratio	功率 Power	LA	LB	LC	LZ	LG	LH	LM	DL	DM	LE	LF	DF	SH	HD	LJ	LT	LR	LS	Q	DS	S	ST	W	T	U	QK
170	ZDG□	7-9-10	1000	190	165	170	14	16	22	91	167	167	53	178	120	47	6	100	M8深12	156	247	82	118	50	M10深20	14	9	53.5	70
170	ZDG□	7-9-10	1500	190	165	170	14	16	22	91	167	167	53	144	120	47	6	100	M8深12	156	247	82	118	50	M10深20	14	9	53.5	70
170	ZDG□	7-9-10	2000	190	165	170	14	16	22	91	167	167	53	144	120	47	6	100	M8深12	156	247	82	118	50	M10深20	14	9	53.5	70
170	ZDG□	7-9-10	2500	190	165	170	14	16	22	91	167	167	53	144	120	47	6	100	M8深12	156	247	82	118	50	M10深20	14	9	53.5	70
170	ZDG□	3.67-4-5-7-9-10	3000	190	165	170	14	16	22	101	167	167	53	154	120	47	6	100	M8深12	156	257	82	118	50	M10深20	14	9	53.5	70
170	ZDG□	3.67-4-5-7-9-10	3500	190	165	170	14	16	22	101	167	167	53	154	120	47	6	100	M8深12	156	257	82	118	50	M10深20	14	9	53.5	70
170	ZDG□	3.67-4-5-7-9-10	4000	190	165	170	14	16	22	101	167	167	53	154	120	47	6	100	M8深12	156	257	82	118	50	M10深20	14	9	53.5	70
170	ZDG□	3.67-4-5-7-9-10	4500	190	165	170	14	16	22	101	167	167	53	154	120	47	6	100	M8深12	156	257	82	118	50	M10深20	14	9	53.5	70
170	ZDG□	3.67-4-5-7-9-10	5000	190	165	170	14	16	22	101	167	167	53	154	120	47	6	100	M8深12	156	257	82	118	50	M10深20	14	9	53.5	70
170	ZDG□	33-35-40-45-50-70	750	190	165	170	14	16	22	113	167	130	53	166	120	47	6	100	M8深12	156	269	82	118	50	M10深20	14	9	53.5	70
170	ZDG□	100	200	190	165	170	14	16	22	97	167	118	53	150	120	47	6	100	M8深12	156	253	82	118	50	M10深20	14	9	53.5	70
170	ZDG□	81-100	400	190	165	170	14	16	22	97	167	118	53	150	120	47	6	100	M8深12	156	253	82	118	50	M10深20	14	9	53.5	70
170	ZDG□	81-100	750	190	165	170	14	16	22	104	167	130	53	157	120	47	6	100	M8深12	156	260	82	118	50	M10深20	14	9	53.5	70
170	ZDG□	11-15.4-20-21-25 33-35-40-45-50-70	1000	190	165	170	14	16	22	125	167	130	53	178	120	47	6	100	M8深12	156	281	82	118	50	M10深20	14	9	53.5	70
170	ZDG□	11-15.4-20-21-25 33-35-40-45-50-70	1500	190	165	170	14	16	22	125	167	130	53	178	120	47	6	100	M8深12	156	281	82	118	50	M10深20	14	9	53.5	70
170	ZDG□	11-15.4-20-21-25 33-35-40-45-50	2000	190	165	170	14	16	22	125	167	130	53	178	120	47	6	100	M8深12	156	281	82	118	50	M10深20	14	9	53.5	70
170	ZDG□	11-15.4-20-21-25 33-35-40-45-50	2500	190	165	170	14	16	22	125	167	130	53	178	120	47	6	100	M8深12	156	281	82	118	50	M10深20	14	9	53.5	70
170	ZDG□	11-15.4-20-21-25 33-35-40-45	3000	190	165	170	14	16	22	135	167	167	53	188	120	47	6	100	M8深12	156	291	82	118	50	M10深20	14	9	53.5	70
170	ZDG□	11-15.4-20-21-25	3500	190	165	170	14	16	22	135	167	167	53	188	120	47	6	100	M8深12	156	291	82	118	50	M10深20	14	9	53.5	70
170	ZDG□	11-15.4-20-21-25	4000	190	165	170	14	16	22	135	167	167	53	188	120	47	6	100	M8深12	156	291	82	118	50	M10深20	14	9	53.5	70
170	ZDG□	11-15.4-20-21	4500	190	165	170	14	16	22	135	167	167	53	188	120	47	6	100	M8深12	156	291	82	118	50	M10深20	14	9	53.5	70
170	ZDG□	11-15.4	5000	190	165	170	14	16	22	135	167	167	53	188	120	47	6	100	M8深12	156	291	82	118	50	M10深20	14	9	53.5	70

技术资料 TECHNICAL DATA

■ 马达安装步骤 Motor Installation Procedure

- ① 拭去马达轴上的防腐剂、油分等。
Wipe on motor shaft, oil and other preservatives.
- ② 取下橡胶帽、转动输出轴、把螺栓头对准橡胶帽孔。此时，请确认固定螺栓已松开。
Remove the rubber plug, rotation of the output shaft, the bolt head alignment hole rubber. At this point, please confirm that the fixed bolt has been loosened.
- ③ 把减速机的马达安装面朝上，放置在平坦的地方保持减速机垂直。
The motor of the reducer is arranged on the face up and placed in a flat place to maintain the vertical speed reducer.
- ④ 马达轴慢慢地插入输出轴内，切勿受到撞击。插入后请确认马达法兰面与减速机法兰面是紧密贴合的。
The motor shaft is slowly inserted into the output shaft, not subject to impact. Please confirm that the flange of the motor is closely related to the reducer flange.
- ⑤ 使用指定的拧紧扭矩拧紧马达安装螺栓。
Use the specified tightening torque tightening motor mounting bolt.
- ⑥ 使用扭矩扳手等按照指定的拧紧扭矩把固定螺栓拧紧。
Use a torque wrench to tighten the fastening bolts according to the specified tightening torque.
- ⑦ 把橡胶帽装上后，作业完了。
After the rubber plug is installed, the job is finished.

● 螺栓拧紧扭矩 Motor Combination Fastening Torque

螺栓尺寸 Bolt Size	马达安装螺栓 Motor Mounting Bolt		固定螺栓 Fixed Bolt	
	Nm	Kgfm	Nm	Kgfm
M3	1.0	0.10	1.8	0.18
M4	2.3	0.23	4.3	0.44
M5	4.7	0.48	8.7	0.89
M6	8.0	0.82	15	1.50
M8	19	1.90	36	3.70
M10	38	3.90	72	7.30
M12	67	6.80	-	-

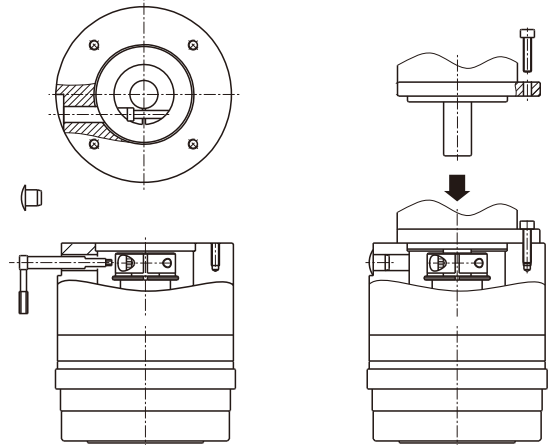

■ 减速机的安装 Installation Of Retarder

减速配减速机时，先确认安装面是否平坦或有毛边等异物，请使用扭矩扳手按指定扭矩进行安装固定。

Reducer reducer with, to confirm the mounting surface is flat or rough foreign matter, please use the torque wrench according to specified torque are fixed.

● 减速机安装螺栓的拧紧扭矩 Tightening Torque Of The Gear Reducer

段位号 Dan No.	螺栓尺寸 Bolt Size	拧紧扭矩Tightening Torque	
		Nm	Kgfm
60	M5	6.2	0.63
90	M8	26	2.70
120	M10	51	5.20
170	M12	89	9.10

※推荐螺栓: 强度划分在12.9以上

※Recommended bolt: The strength of more than 12.9

● 延长轴输出型(ZDGS)及法兰输出型(ZDGF)的机械安装尺寸精度请参照下图。

Extended shaft output type (ZDGS) and flange type (ZDGF) of mechanical installation size accuracy, please refer to the following figure.

(单位:mm)

● 延长轴输出型(ZDGS) Extended Shaft Output (ZDGS)

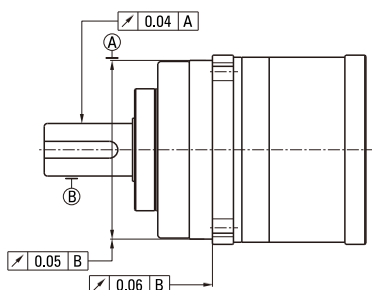

■ 安装输出法兰部 只限ZDGF (法兰部) Install output flange ZDGF only (flange)

安装到输出法兰部时，请使用扭矩扳手按指定扭矩安装固定。
When installing to the output flange, use the torque wrench to install the fixed torque.

● 输出法兰的螺栓拧紧扭矩 Output Flange Bolt Tightening Torque

段位号 Dan No.	螺栓尺寸 Bolt Size	拧紧扭矩Tightening Torque	
		Nm	Kgfm
60	M4	4.3	0.44
90	M6	15	1.50
120	M8	36	3.70
170	M8	36	3.70

※推荐螺栓: 强度划分在12.9以上

※Recommended bolt: The strength of more than 12.9

● 法兰输出型(ZDGF) Flange Type (ZDGF)

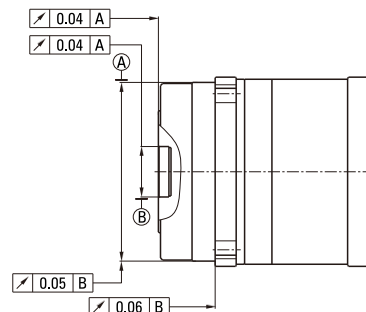

马达对应表 (输入转速为3,000RPM时) MOTOR MATCHING TABLE (WHEN INPUT SPEED IS 3,000RPM)

对应表 Matching Table

生产厂家 Motor Manufacturer	马达系列 Motor Series	马达功率 Motor Power (W)				
		50W	100W	200W	400W	750W
松下电器产业(株) Panasonic	MSM	T1				
	MSMA	T1				
	MSMD	T1				
	MUMA	标准外 Out of standard	标准外 Out of standard	T1		
	MBMK	T1	标准外 Out of standard	T1		
	MUMS	标准外 Out of standard				
(株)安川电机 Yaskawa electric	SGM	T2				
	SGMAH	T2				
	SGMAS	T2				
	SJME	无对象 No subject	T2			
	SGMJV	T3				
	SGMAV	T3				
三菱电机(株) Mitsubishi electric	HC-KF	T3				
	HC-KFS	T3				
	HC-MF	T3				
	HC-MFS	T3				
	HA-ME	T3				
	HC-PQ	T3			无对象 No subject	
	HC-KQ	T3			无对象 No subject	
	HF-KP	T3				
欧姆龙(株) Omron	R88M-U	T2				
	R88M-W	T2				
	R7M-A	T2				
	R7M-Z	T2				
富士电机机器控制(株) Fuji electric systems	GY5※	T2				
山洋电气(株) Sanyo Denki	P30B	T3			T2	
	Q1	T3			标准外 Out of standard	
(株)吉恩思 Keyence	MV	T3			标准外 Out of standard	
东芝电机(株) Toshiba machine	VLBSV-Z※	标准外 Out of standard		T3		
	VLBSV-ZA※	标准外 Out of standard		T3		
	VLBSVT	标准外 Out of standard		T3		标准外 Out of standard
多摩川精机(株) Tamagawa seiki	TBL-i※	T3			无对象 No subject	
	TBL-ii※	T3			标准外 Out of standard	
日机电转(株) Nikki denso	NA50	T1				
	NA70※	T3			无对象 No subject	
	NA80※	T3			标准外 Out of standard	
(株)三明 Sanmei	TS※	T3			标准外 Out of standard	
	SS※	T3			标准外 Out of standard	
(株)日立产机系统 Hitachi industrial equipment systems	ADMA	T3			标准外 Out of standard	
三木普利 Miki pulley	SA3	T1				

注1)没有油封和尺寸不同时，安装带油封的马达有时需特别订货。

If an oil-seal is not present and the size is different, attachment of the oil-seal may correspond to special order, in some cases.

注2)马达轴为D形轴、锥形时需要特别订货。

If the motor shaft is of D-cut and taper type, it corresponds to a special order.

注3)因马达功率（适用表中带※的马达）与减速比的组合，出现瞬间最大输出扭矩时，产生的轴向力有时会超过伺服马达容许轴向力，因此，需要注意。

Note that thrust power arising out of instantaneous max. output torque by the combination of motor capacity (motor of the motor series table) and reduction ratio may exceed permissible thrust power of the servo motor.

注4)标准外有时需要特别订货。欲知详情，请另外与本公司联系。

Out-of-standard may correspond to a special order in some cases, For details, contact us.

马达对应表 (输入转速为3,000RPM时)

MOTOR MATCHING TABLE (WHEN INPUT SPEED IS 3,000RPM)

对应表 Matching Table

生产厂家 Motor Manufacturer	马达系列 Motor Series	马达功率 Motor Power (W)								
		1000W	1500W	2000W	2500W	3000W	3500W	4000W	4500W	5000W
松下电器产业(株) Panasonic	MSM	T1								
	MSMA	T1								
(株)安川电机 Yaskawa electric	SGMS	T2			无对象No subject	T2	无对象No subject	T2	无对象No subject	T2
	SGMSH	T2			无对象No subject	T2	无对象No subject	T2	无对象No subject	T2
	SGMSS	T2				无对象No subject	T2	无对象No subject	T2	
三菱电机(株) Mitsubishi electric	HC-RF	T3			无对象No subject	T3	无对象No subject	T3	无对象No subject	T3
	HC-RFS	T3			无对象No subject	T3	无对象No subject	T3	无对象No subject	T3
	HC-RP	T3			无对象No subject	T3	无对象No subject	T3	无对象No subject	T3
欧姆龙(株) Omron	R88M-U	T2			无对象No subject	T2	无对象No subject	T2	无对象No subject	T2
	R88M-W	T2			无对象No subject	T2	无对象No subject	T2	无对象No subject	T2
富士电机机器控制(株) Fuji electric systems	GYS	T3			无对象No subject	T2	无对象No subject	T2	无对象No subject	T2

下列系列马达也可以标准方式适应 Standard Compatibility With The Following Motor Series

生产厂家 Motor Manufacturer	马达系列 Motor Series	马达功率 Motor Power (W)
三菱电机(株) Mitsubishi electric	HC-SFS※	500W,1000W,1500W,2000W,3500W
	HF-SP	
(株)安川电机 Yaskawa electric	SGMP	100W,200W,400W,750W,1500
	SGMPH	
	SGMPS	
松下电器产业(株) Panasonic	MQMA	100W,200W,400W
欧姆龙(株) Omron	R88M-WP	100W,200W,400W,750W,1500W
	R7M-AP	100W,200W,400W,750W
富士电机机器控制(株) Fuji electric systems	GYS	100W,200W,400W
发那科(株) Fanuc	BIS※	200W,400W,500W,750W,1200W

注1)没有油封和尺寸不同时, 安装带油封的马达有时需特别订货。 注2)马达轴为D形轴、锥形时需要特别订货。 注3)因马达功率(适用表中带※的马达)与减速比的组合, 出现瞬间最大输出扭矩时, 产生的轴向力有时会超过伺服马达容许轴向力, 因此, 需要注意。 注4)标准外有时需要特别订货。欲知详情, 请另外与本公司联系。

Note1) If an oil-seal is not present and the size is different, attachment of the oil-seal may correspond to special order, in some cases. Note2) If the motor shaft is of D-cut and taper type, it corresponds to a special order. Note3) Note that thrust power arising out of instantaneous max. output torque by the combination of motor capacity (motor of the motor series table) and reduction ratio may exceed permissible thrust power of the servo motor. Note4) Out-of-standard may correspond to a special order in some cases. For details, contact us.

除上述伺服马达厂家外, 本公司减速机还适配以下伺服马达厂家。安装方式请咨询本公司。

Our gearbox can match to servo motor of followings manufacturers, including above. Please ask us about the assembly.

神钢电机(株)	日本电产三协	中达电通	路斯特	博世力士乐
FANUC	POCKWELL	山洋	多摩川	基恩斯
东芝机械	日机装	三明	日立产机系统	三木普利

其他 etc.

Blank page with horizontal dashed lines for writing.

Blank page with horizontal dashed lines for writing.

CATALOGUE



PLANETARY GEAR BOX
ZB/E系列
高精度行星减速机

ZD 中大力德



TRANSMISSION PLANETARY
传动行星减速机

ZD 中大力德



DC BRUSHLESS GEAR MOTOR
直流无刷减速机

ZD 中大力德



AC & DC GEAR MOTOR
微型交、直流减速机

ZD 中大力德



AC & DC RIGHT
ANGLE GEAR MOTOR
交、直流直角减速机

ZD 中大力德



SMALL AC GEAR MOTOR
小型交流平行轴齿轮减速机

ZD 中大力德

PLANETARY GEAR BOX CATALOGUE

宁波中大力德智能传动股份有限公司
NINGBO ZHONGDA LEADER INTELLIGENT TRANSMISSION CO.,LTD.

地址：浙江省慈溪高新技术产业开发区新兴一路185号
Add : NO.185 1st Xinxing Road, New Industrial Zone, Cixi City, Zhejiang, China.

宁波中大创远精密传动设备有限公司
ZHONGDA CHUANGYUAN PRECISE TRANSMISSION EQUIPMENT CO.,LTD.

地址：浙江省慈溪市杭州湾新区金慈路159号
Add : No.159 Jinci Road, Hangzhou Bay District, Cixi City, Zhejiang, China.

国内贸易服务：

电话：86-574-63537377
传真：86-574-63534879
E-mail: china@zd-motor.com

国际贸易服务：

International trade department:
Tel: 86-574-63530538 Fax: 86-574-63534879
E-mail: manager@zd-motor.com
E-mail: trade@zd-motor.com

更多详情，敬请浏览：
www.zd-motor.com